

Product Features

- Sealed transmitter within the sensor
- Field re-programmable with interface module and software
- RTD sensor input
- 4-20mA linearized signal output
- Large 4-digit LED display
- Easy installation
- All Stainless Steel 316 construction

Description

The DTG Digital Temperature Gauge is a complete solution for most industrial temperature monitoring and temperature indicating applications. Simply constructed, this gauge features a bright and large 4-digit red LED display with an analog 4-20 mA output. Based on Intempco's patented MIST technology, the DTG is designed for optimum accuracy and performance. The DTG is an ideal replacement for bi-metal, liquid bulb and gas thermometers.

The DTG can be factory calibrated to customer specified temperature range. As with any other TST series sensor, the DTG's built-in programmable transmitter can be re-scaled and re-calibrated using the optional interface module and software. Housing, probe and fitting material is all fabricated from Stainless Steel 316. Standard extension cables offered are PVC or Silicon insulated wires.

The DTG arrives factory scaled and calibrated to the customer's specified temperature range. No costly field calibration is required. If the application changes, the DTG can be re-scaled at any range within the sensor limits while maintaining its accuracy. No re-calibration requiring costly temperature baths is necessary. Reprogramming is done with the optional interface module and software.



Application / Process Notes

- General purpose and industrial applications
- Ideal replacement for bi-metal, liquid bulb and gas thermometers
- Resistant to moisture and vibration

Order from: **C A Briggs Company**
622 Mary Street; Suite 101; Warminster, PA 18974
Phone: 267-673-8117 - 800-352-6265; Fax: 267-673-8118
Sales@cabriggs.com - www.cabriggs.com

DTG

Digital Temperature Gauge
w/ Programmable 4-20 mA Output

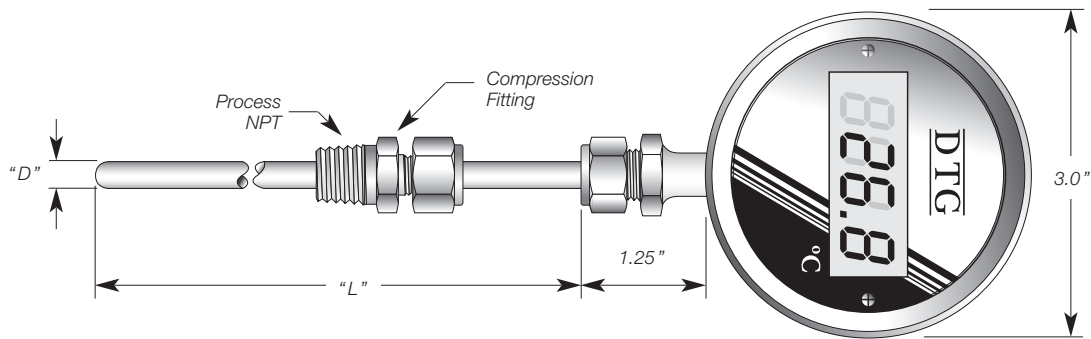

Ordering Information :

MODEL 1 2 3 4 5 6 7

DTG - [] - [] - [] - [] - [] - [] - []

BOX1 CODE	Calibrated Temperature Range
05	0 to 50 °C (32/122 °F)
10	0 to 100 °C (32/212 °F)
15	0 to 150 °C (32/302 °F)
20	0 to 200 °C (32/392 °F)
55	-50 to 50 °C (-58/122 °F)
51	-50 to 150 °C (-58/302 °F)
52	-50 to 200 °C (-58/392 °F)
L*	-50 to 200 °C (-58/392 °F) range

* Code **L** is not factory calibrated. Requires customer calibration using the **DTG PKIT-1**.

Notes:

- DTG sensors are factory calibrated to accuracy of $\pm 0.25\%$ of span or better.
- For non-standard temperature ranges indicate desired value in °C or °F in Box1 or see website www.intempco.com.
E.g.: DTG03-(40/120C)-CU...
- Order **DTG PKIT-1** for sensor customization.

BOX2 CODE	Output Type
CU	4-20mA source 3-wire, upscale burnout
CD	4-20mA, source 3-wire downscale burnout

BOX3 CODE	Probe Dia. "D" & Mat'l
4S	1/4", 316 Stainless Steel
6S	3/8", 316 Stainless Steel
8S	1/2", 316 Stainless Steel

BOX4 CODE	Probe Length "L"
---	In 0.1" increments Ex.: 065 = 6.5" long, 120 = 12" long

BOX5 CODE	Fitting Type
N	None
D	1/4" NPT (max. probe .312" dia.)
F	3/8" NPT (max. probe .375" dia.)
H	1/2" NPT
L	3/4" NPT

Note: Fitting material is Stainless Steel SS316

BOX6 CODE	Extension Wire Type
PV	PVC Insulation, 80 °C (176 °F) max.
SL	Silicone Insulation, 180 °C (356 °F) max.

BOX7 CODE	Lead Wire Length "E"
---	In Inches Ex.: 060 = 60" long

TECHNICAL SPECIFICATIONS

@ Vnom. = 24 VDC, T ambient = 25 °C, Min. Span = 100 °C

Electrical Properties

Sensor :	RTD, type Pt100
Sensor Temperature Ranges :	See DTG table for standard ranges. Field re-scalable between -200°C to 600°C or -50°C to 200°C, depending on model.
Output :	4-20 mA (3-wire configuration), linear to temperature
Power Supply :	12-36 VDC, polarity protected
Supply Effect :	0.001%/V
Current Consumption :	15 mA @ 24VDC + current output (950mW Max)
Accuracy :	± (.25°C + 0.40% of span) with one-point calibration ¹ . ± (.10°C + 0.20% of calibrated span) with two-point calibration ² .
Display :	4-Digit LED (decimal point programmable by software)
Display Resolution :	± 0.02% of range ± 1 Digit
Maximum Loop Resistance :	[(Vsupply – 7) * 40] ohms
Sensor Open Circuit :	Upscale 24 mA or Downscale 2.5 mA with error message on display
Warmup :	30 seconds
RFI Effect :	1% or less typical
Isolation :	500 VDC Input/Output
Temp. Effects :	± 0.001% of Span / °C
Long Term Drift :	≤ 0.1% FS/Year

Mechanical Properties

Probe and Housing Material :	Stainless Steel 316, welded to probe
Cable Material :	PVC, Silicone
Window Material :	Lexan
Protection:	NEMA 4X (IP65)
Storage Temp. Range:	-40°C to 80°C
Operating Temp. Range:	-40°C to 80°C (housing only)
Maximum Operating Pressure:	1500 PSIG Max (probe only)

¹. Max. error on complete span. Error at calibration point ≤ 0.1% of Span.

². Max. error on complete calibrated span. Error at calibration points ≤ 0.1% of Span.