

**Operating Instructions
for
Temperature Sensor**

Model: TSA

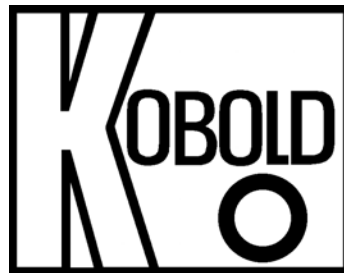

1. Contents

1. Contents.....	2
2. Note	3
3. Regulation Use.....	3
4. Operating Principle.....	3
5. Instrument Inspection.....	4
6. Mechanical Connection.....	4
7. Electrical Connection	4
8. Technical Information.....	5
9. Ordering Details	6
10. Maintenance	6
11. Dimensions	7

Manufactured and sold by:

Kobold Messring GmbH
Nordring 22-24
D-65719 Hofheim, Germany
Tel.: +49 (0)6192-2990
Fax: +49(0)6192-23398
E-Mail: info.de@kobold.com
Internet: www.kobold.com

2. Note

Please read these operating instructions before unpacking and putting the unit into operation. Follow the instructions precisely as described herein.

The devices are only to be used, maintained and serviced by persons familiar with these operating instructions and in accordance with local regulations applying to Health & Safety and prevention of accidents.

By usage in machines, the measuring unit should be used only when the machines fulfil the EWG-machine guidelines.

As per the “Pressure Equipment Directive 97/23/EC”

No CE marking, see Article 3, Section 3 "Sound Engineering Practice", Directive 97/23/EC

Diagram 6, Piping, Group 1, Dangerous Fluids

3. Regulation Use

The Temperature Sensor, model: TSA, is to be installed only in the specified applications. Any usage which exceeds the specifications may invalidate its warranty. Therefore any resulting damage is not the responsibility of the manufacturer. The user assumes all risk for such usage. The application specifications include the installation, start-up and service requirements specified by the manufacturer.

4. Operating Principle

Model TSA Temperature Sensors respond quickly and are designed to work from -40 to +150 °C. The measuring device is a laser-trimmed electronic sensor enclosed in a sturdy brass or stainless steel housing and is suitable for harsh industrial applications.

Laser trimming allows a high output signal at the temperature sensor to be achieved with respect to the measured temperature change. This system means that no line compensation is required for cabling under 20 meters.

This relationship is linear with positive temperature coefficients. For evaluation of the output signal control and indicating instruments, which allow a flexible application in a wide range of installations, are being used.

The sensors come in a housing with female threaded connections on both sides (G 1/4" to G 1 1/2") and a 1.5 m connection cable with a silicone jacket.

5. Instrument Inspection

Instruments are inspected before shipping and sent out in perfect condition. Should the damage to a device be visible, we recommend a thorough inspection of the delivery packing. In case of damage, please inform your parcel service/ forwarding agent immediately, since they are responsible for damages during transit.

Scope of supply:

The standard delivery includes the following:

- Temperature sensor model: TSA
- Operating instructions

6. Mechanical Connection

Before installation:

- Remove all packing materials and transport retainers and ensure that no such materials remain in the device.
- Make sure that the maximum operating pressures and temperatures will not be exceeded in the intended installation of the device (see “Technical Information”).
- Install the temperature sensor tension-free in the piping.
- This device must not be installed within an induction field.
- If possible, after completing the mechanical installation, immediately check the threaded connection between the device and the piping for leakage.

7. Electrical Connection

The temperature sensor is connected with a two-wire silicone cable. The polarity of the connection does not matter.

8. Technical Information

Materials

Housing:	Brass or stainless steel 1.4301
Gasket:	Viton
Cable:	1.5 m silicone cable

Max. operating pressure:

Brass:	16 bar
Stainless steel:	25 bar

Max. medium temperature: - 60 to +180 °C

Max. supply current: 1 mA

Accuracy:

Model TSA-0...:	at 20°C: ± 0.7°C over entire range of measurement: ± 2.5°C
Model TSA-1...:	Class B as per IEC 751

For further data, see “Resistance Thermometer” documentation

Tolerance class:	1/3 Class B
Tolerance in K	± (0.10 K + 0.0017 x t)
Tolerance at	
t=0 °C	± 0.10 K
t=100 °C	±0.27 K

Resistance values at different temperatures

Model TSA-0...

(with 1 mA max. supply current)		(with 1 mA max. supply current)	
Temperature	Resistance (Ω)	Temperature	Resistance (Ω)
- 40°C	1584 ± 12 (1.9°C)	+ 60°C	2314 ± 9 (1.1°C)
- 30°C	1649 ± 11 (1.7°C)	+ 70°C	2397 ± 10 (1.2°C)
- 20°C	1715 ± 10 (1.5°C)	+ 80°C	2482 ± 12 (1.4°C)
- 10°C	1784 ± 9 (1.3°C)	+ 90°C	2569 ± 14 (1.6°C)
0°C	1854 ± 8 (1.1°C)	+100°C	2658 ± 16 (1.8°C)
+10°C	1926 ± 6 (0.8°C)	+110°C	2748 ± 18 (2.0°C)
+20°C	2000 ± 5 (0.7°C)	+120°C	2840 ± 19 (2.0°C)
+30°C	2076 ± 5 (0.7°C)	+130°C	2934 ± 21 (2.2°C)
+40°C	2153 ± 6 (0.8°C)	+140°C	3030 ± 23 (2.4°C)
+50°C	2233 ± 7 (0.9°C)	+150°C	3128 ± 25 (2.5°C)

9. Ordering Details

Connection (female thread)	Order number (with NTC sensor)		Order number (with Pt100 sensor)	
	Brass	Stainless steel	Brass	Stainless steel
G 1/4	TSA0105	TSA0205	TSA1105	TSA1205
G 3/8	TSA0110	TSA0210	TSA1110	TSA1210
G 1/2	TSA0115	TSA0215	TSA1115	TSA1215
G 3/4	TSA0120	TSA0220	TSA1120	TSA1220
G 1	TSA0125	TSA0225	TSA1125	TSA1225
G 1 1/4	TSA0132	TSA0232	TSA1132	TSA1232
G 1 1/2	TSA0140	TSA0240	TSA1140	TSA1240

10. Maintenance

This temperature sensor is maintenance-free. If it is necessary to remove accumulated dirt, loosen the sleeve nut and remove the sensor for cleaning.

Caution! Before removing the sensor, be sure to relieve the pressure in the piping and drain it of fluid.

11. Dimensions

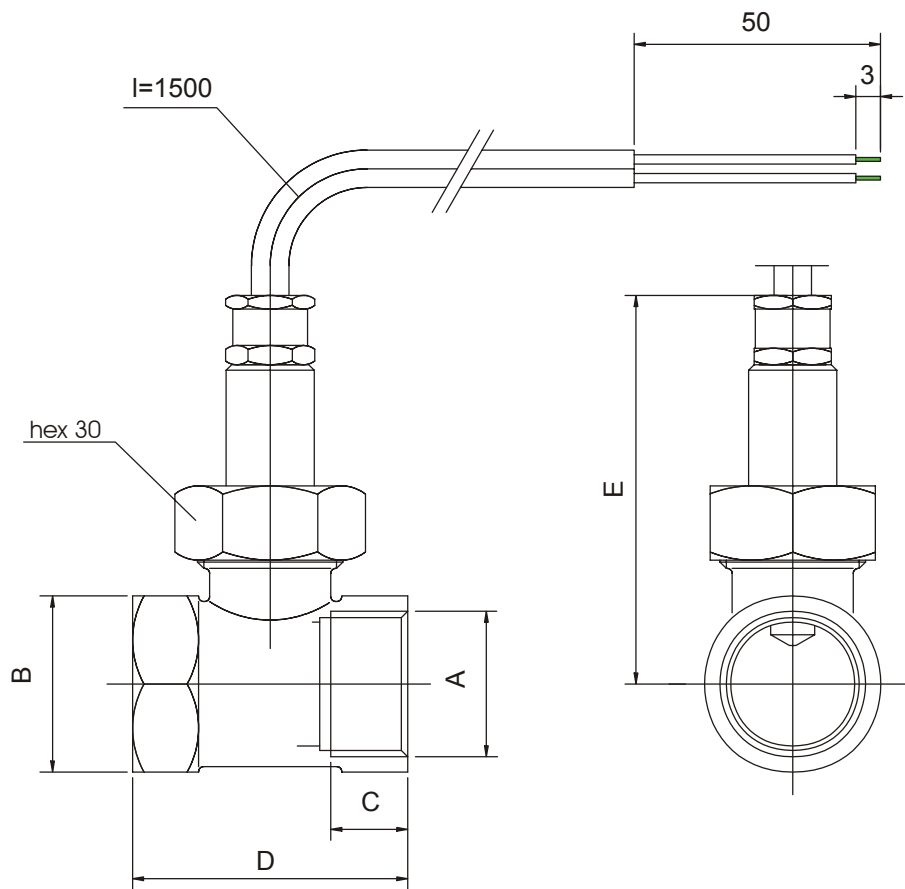

(mm)

A	B (hex)	C	D	E max.
G 1/4"	27	10	50	77
G 3/8"	27	10	50	77
G 1/2"	27	10	50	77
G 3/4"	32	15	52	78
G 1"	39	15	56	81
G 1 1/4"	46	15	50	109
G 1 1/2"	55	15	50	116