

Operating Instructions for Electronic Pressure Switch

Model: PSC



Content

1. Foreword	3
2. Pressure switch description	5
3. Start of operation	6
4. Switching on and of	8
5. Programming	8
6. Technical data	15
7. CE-conformity	17
8. Maintenance	18
9. Troubleshooting	18
10. Cleaning	18
11. Disposal	18

1. Foreword

Thank you for the confidence that you have shown in Kobold by purchasing the PSC pressure switch.

Like all other Kobold products, PSC pressure switches are a combination of customer requirements, state-of-the-art technology, modern manufacturing and stringent quality control.

These model series meet the demand for extremely good functionality.

The pressure switch has a 4-digit digital display, 2 switching points that switch to N potential or P potential or one switching point and one analogue output. The switching points, the hysteresis / window function and the contact function of each switching point are programmable. Password protection can be activated to provide protection from unauthorised program modifications. The device can be rotated in order to align the LED display and optional to the electrical connection.

These operating instructions have been compiled with care. However, it is impossible to take every possible usage case into consideration. For this reason, if you feel that instructions for your particular usage case are missing, please contact us, and we would be pleased to provide assistance. Please observe the relevant national safety regulations during the installation, start-up and operation of this pressure switch.

Scope

These instructions apply to the Kobold series of PSC pressure switches.

A distinction is made between the version with two switching points and the version with one switching point and one analogue output in individual sections.

The state of technology at the time of delivery always applies, and we reserve the right to make technical changes without notice.

Copyright

All rights to these operating instructions are reserved. These operating instructions, including extracts thereof, must not be copied or translated into other languages without our written permission.

Safety instructions and warnings

Please read these instructions before installing and starting up the pressure switch. Failure to follow the instructions will make all guarantee, warranty and compensation claims null and void.

- Only qualified persons are permitted to install the equipment and make the electrical connection, and the correct tools must always be used.
- Please ensure that the pressure switch is suitable for your application.
- Please check that the materials that come into contact with the medium are compatible with the media that are going to be measured.
- The limits that are specified in the technical data for the pressure switch must be complied with.
- Under regular working-conditions the surface temperature of the housing becomes up to 15K warmer than the ambient temperature. High ambient temperatures can result in surface temperatures which make a protection against contact necessary.
- Please note that the pressure switch can be affected or damaged by strong magnetic fields, erroneous equipotential bonding or other effects.
- The device must not be opened, painted / coated or modified.
- Damaged devices must not be started up. If damage occurs during operation, suitable measures must be taken to prevent persons or property from being put at risk by the damaged pressure switch.
- The switch must only be repaired by Kobold.

The accepted technical regulations and all national regulations must always be observed and complied with.

Exclusion of liability

Kobold guarantees that the pressure switch is in perfect working condition when it is delivered. The basis consists of the technical data in the data sheet and these operating instructions.

Liability cannot be accepted for the suitability of the pressure switch.

Usage for any other purpose than the ones that are mentioned in „Correct purpose of use“ is not permitted.

Claims for compensation will only be entertained by Kobold in the event of intent or gross negligence. Responsibility for damage to equipment, systems or the surroundings of the pressure switch will not be accepted.

No liability is accepted for damage caused by incorrect operation.

The haulage contractor is responsible for damage that occurs in transit.

2. Pressure switch description

The pressure switch has one analogue output and one switch output (model PSC-2) or two switch outputs (model PSC-1). The analogue output and the switch output(s) is (are) adjusted using the two buttons: unit, switching point, switchback point(hysteresis / window), switching function (normally closed / normally open contact), delay time, damping and switching to N potential or P potential.

The password protection that can be activated is a special feature, and prevents unauthorised persons from modifying the adjusting parameters.

The optional dual rotating capability makes it possible for the electrical output and the display to be aligned independently.

Correct purpose of use

The equipment is only authorised for proper use for its correct purpose. Failure to do this will invalidate all warranties and release the manufacturer from all responsibility!

The equipment is constructed in compliance with IP65 and should be protected from excessive amounts of water and dust.

The equipment must be installed so that it is protected from external damage.

It must be ensured that the plug is correctly installed and has the relevant IP protection.

The limits specified in the data sheet must be complied with.

3. Start of operation

The accepted technical regulations must be complied with during installation and dismantling. The system component must be depressurised prior to installation and dismantling.

The special safety regulations must be complied with, particularly when working on the electrical system. All connections to external electrical equipment must be made in accordance with technical regulations.

The power to system must always be switched off when the switch is being connected.

The electrical connection is made via the plug attached to the housing.

The plug-in electrical connection must be protected in accordance with the manufacturer's specifications.

The load can be connected to ground (switching to P potential) or to the supply voltage (switching to N potential).

For the assembly the following moments may not be exceeded:

G 1/8 = 15 bis 20 Nm

G 1/4 = 20 bis 25 Nm

G 1/2 = 40 bis 50 Nm

Round connector M 12 x 1 (4-pin)

Signal	Stecker	Colour
Supply: UB	1	brown
Supply: 0V	3	blue
Switch output S 1	4	black
Switch output S 2 or analogue output	2	white

We recommend our accessories round connector please see brochure Z2 control devices and relays.

**switching to p potential
1 switching output and 1 analogue output**

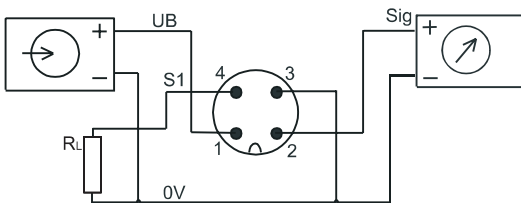

2 switching outputs

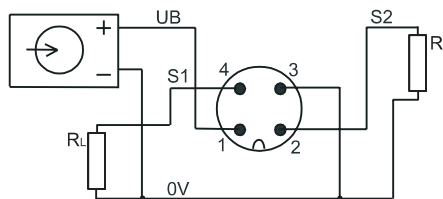

**switching to n potential
1 switching output and 1 analogue output**

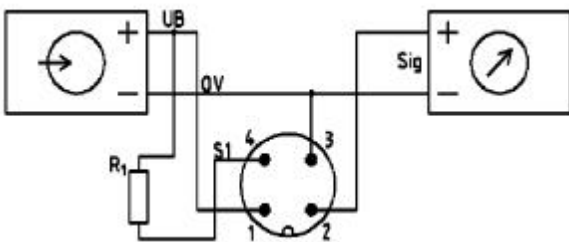

2 switching outputs

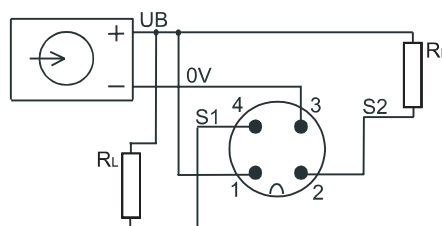

4. Switching on and off

The pressure switch is switched on when the supply voltage is applied. There is no on/off switch. A brief initialisation phase occurs when the supply voltage is applied to the switch. The switch is then in normal operating mode. The operating pressure is shown on the display and the switch outputs are operational. Briefly pressing button S1 causes the switching point 1 setting to be displayed, and pressing button S2 causes the second switching point to be displayed.

5. Programming

The switch is initialised after switching on. The display and the switching point LED illuminate. The nominal pressure is briefly displayed. The outputs are inactive during this time.

After initialisation the switch is in normal operating mode. The pressure appears on the display, the switch outputs are active and the LED's indicate the status of the switch outputs.

Briefly pressing button S1 or S2 causes the relevant switching point to be displayed. The status LED's flash for as long as the switching points are being displayed.

Pressing the buttons for longer (press and hold down button until display flashes) causes the current pressure to be taken over as the switching point. The hysteresis remains unchanged. If the password has been activated (see programming mode) the programming is only accepted after the password has been entered.

The switch output(s) can be programmed using the control buttons without the presence of pressure. The programming sequence must run without interruptions. If delays of about 30 seconds or more occur, the switch automatically exits programming mode and switches to normal mode. All previous changes are lost.

Status-LED switching output

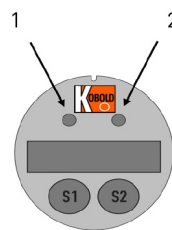

Password

Password protection can be activated in programming mode. The pressure switch is protected from unauthorised setting modifications.

If you forget the password, assistance can be obtained from **Kobold**.

The serial number of the pressure switch will be needed in this case (on the name plate).

Switching points and hysteresis / window

The switching point(s) can also be programmed without the presence of pressure. The decimal points are specified in the factory in accordance with the measuring / adjusting range and the associated accuracy.

Switching function

The switching function (normally closed / normally open contact) is defined individually for each switching point. Each switch output is programmed to switch to P potential or N potential.

Parameter description / programming

-  Version with two switching points
-  Version with one switching point and analogue output
-  Firmware option

Function of the buttons: S1 to run through the menu points, to change the value
S2 to select menu point, to return to the menu point

User menu

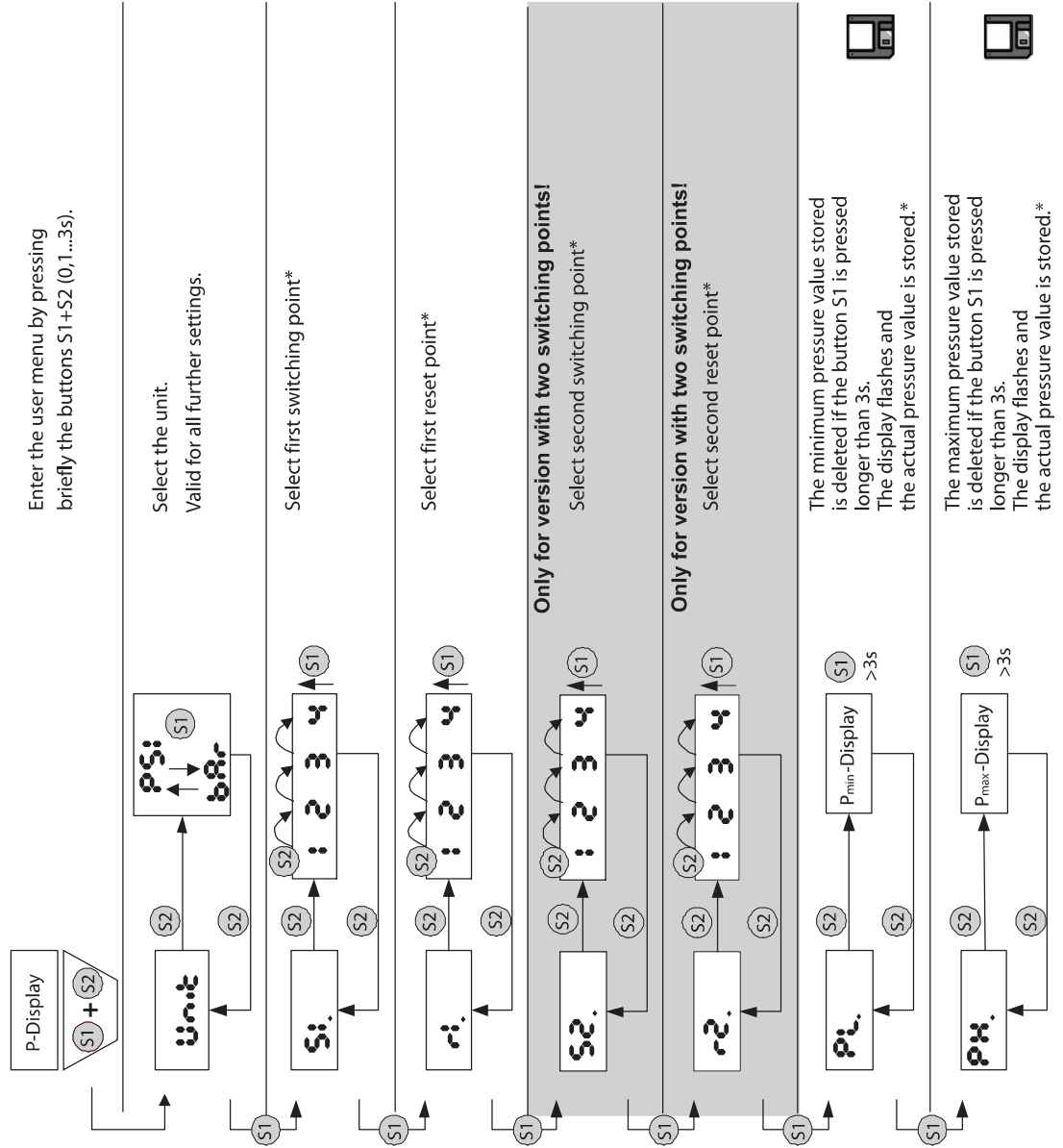

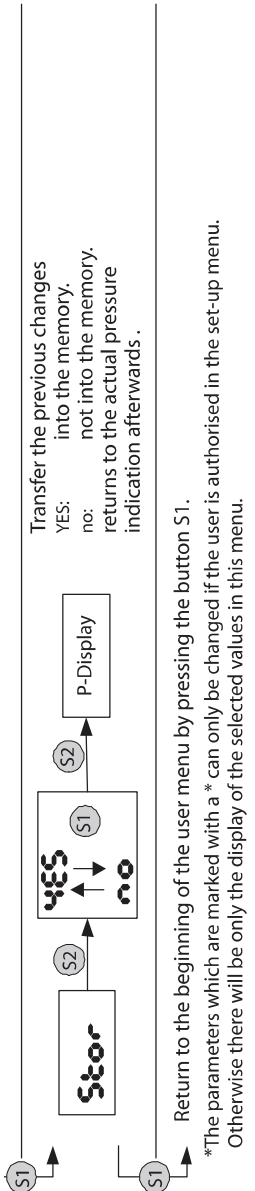

Return to the beginning of the user menu by pressing the button S1.
 *The parameters which are marked with a * can only be changed if the user is authorised in the set-up menu. Otherwise there will be only the display of the selected values in this menu.

Set up menu

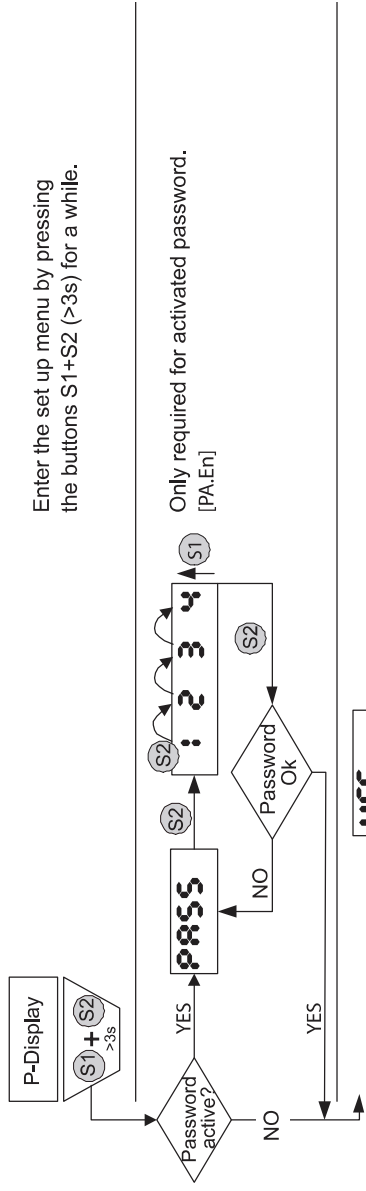

Only required for activated password.
 [PA.En]

Activate password

YES: password is required
 no: password is not required



Change password

Only possible with activated password.
 [PA.En]

Reset-authorisation for the user

The user has the permission
 YES: to delete
 no: do not delete
 the max-min-memory.

Choice of the unit

Applies to all further settings.

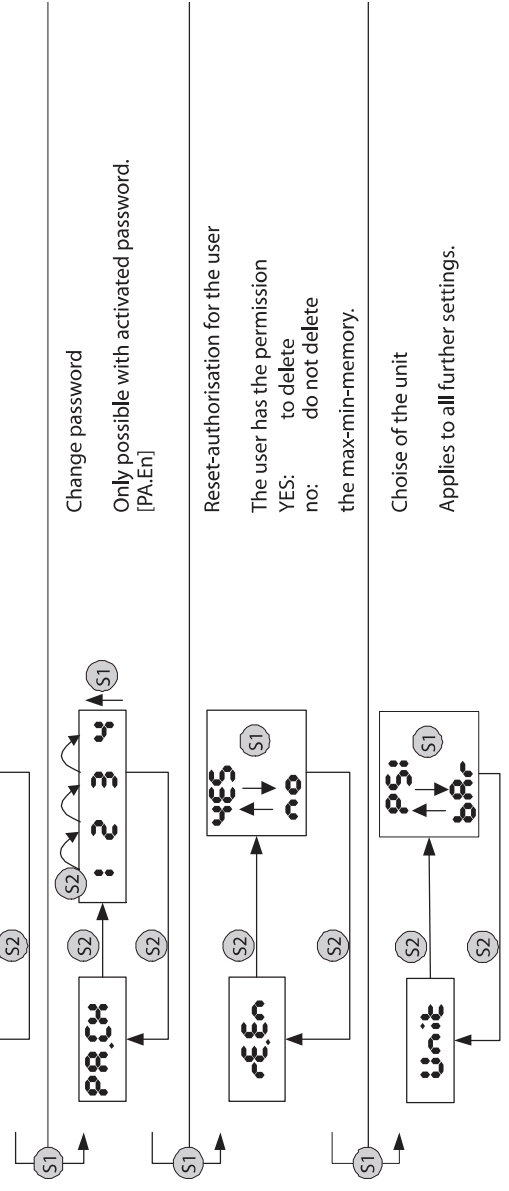

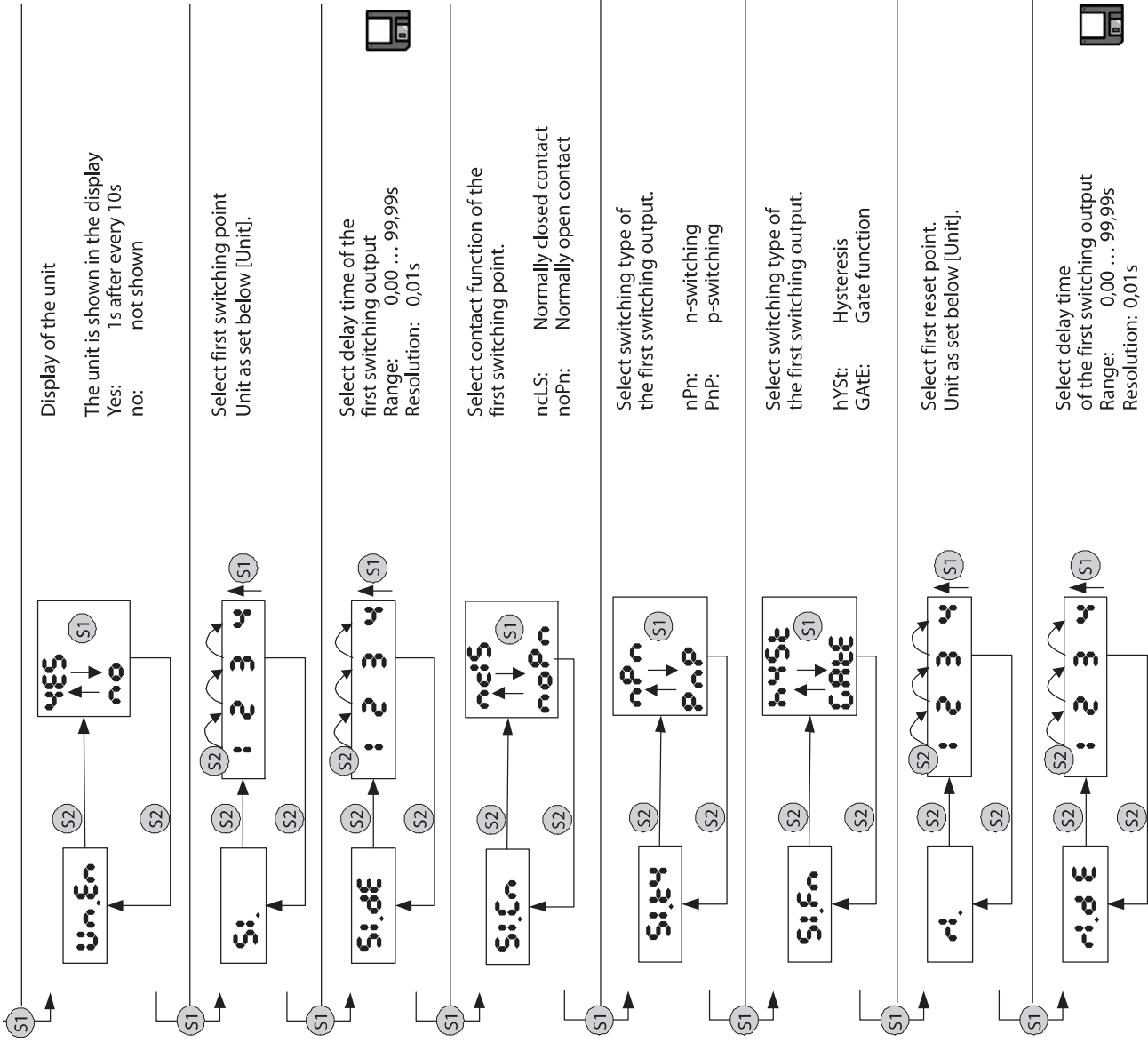

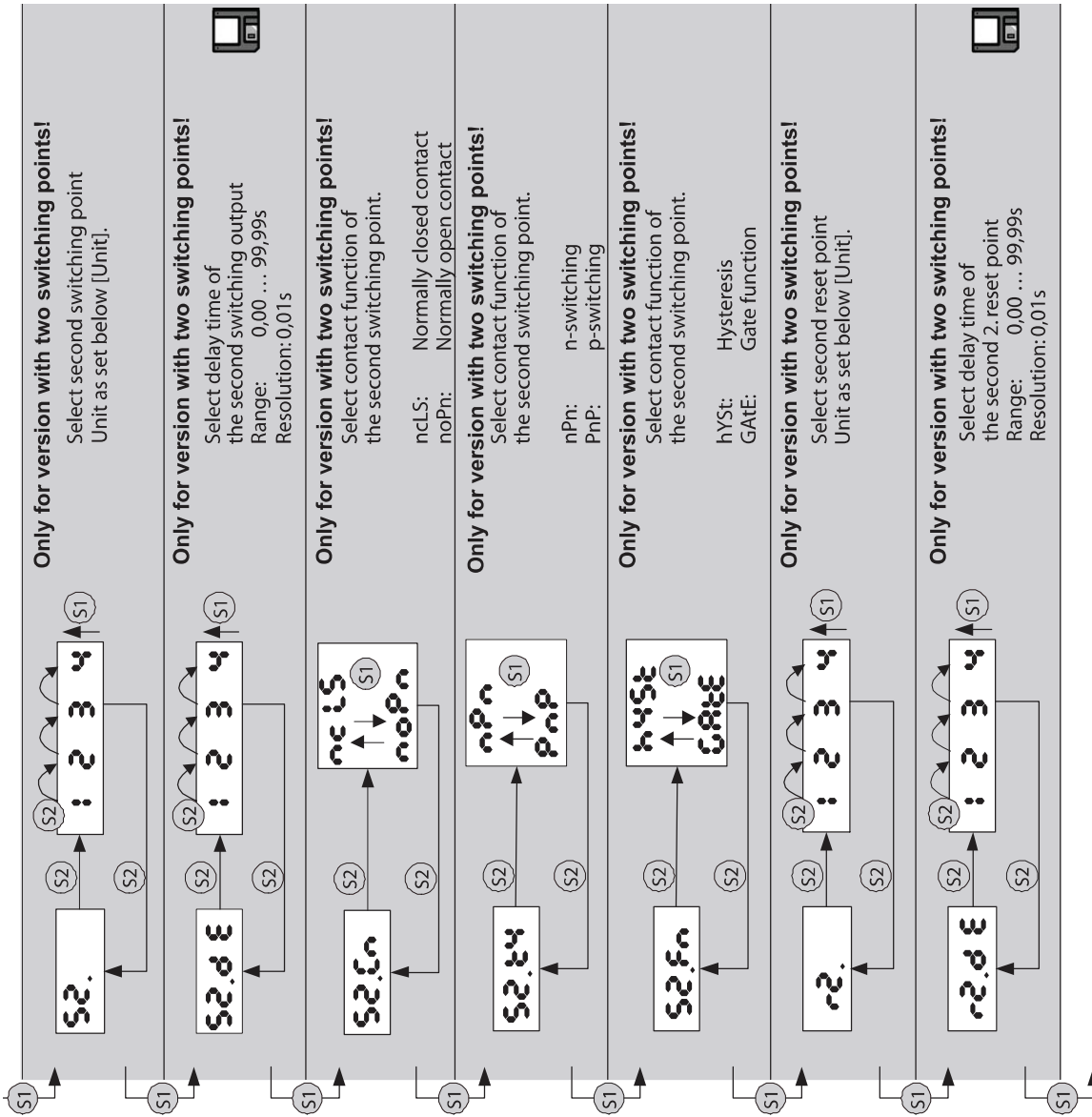

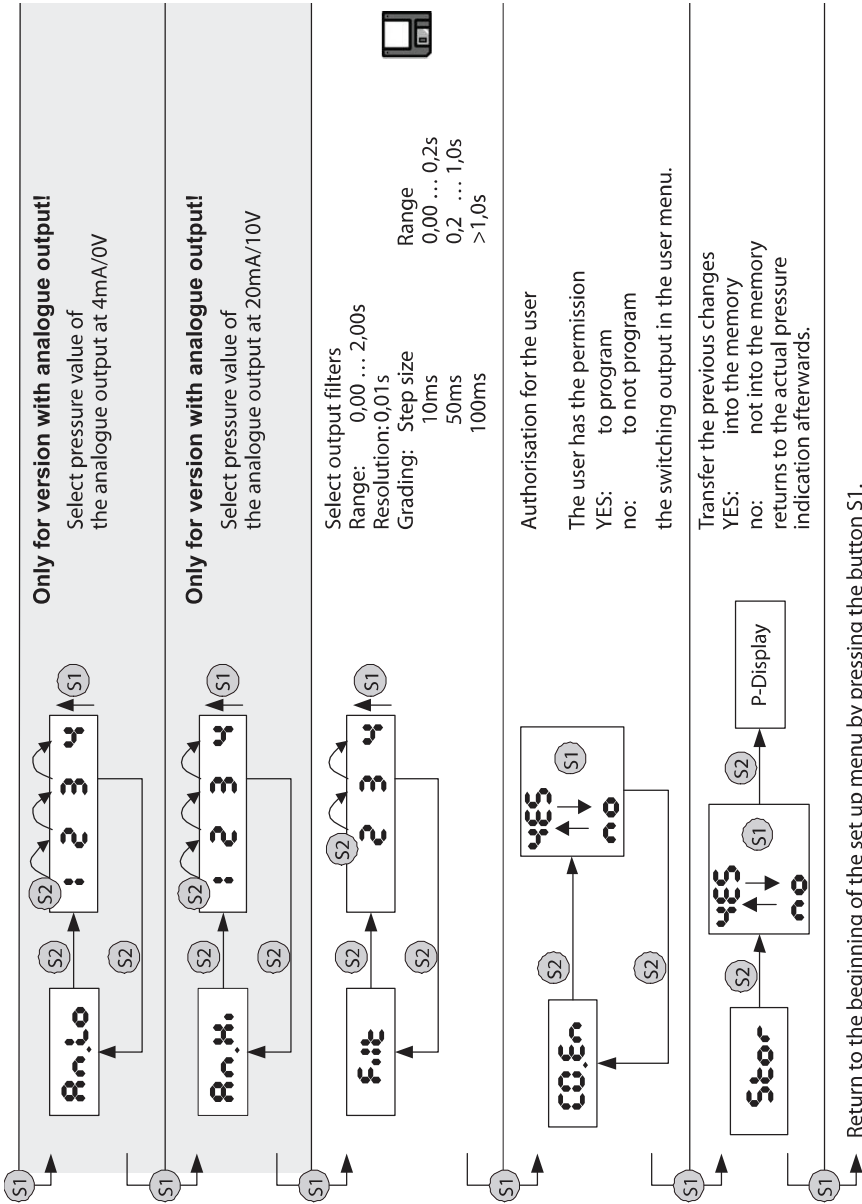

To exit the menu

1. Possibility
After the selection, the menu will automatically be closed whether the modified value is stored or not.
2. Possibility
It is possible to exit the menu anytime by pressing the buttons S1 and S2 simultaneously.
User menu: 0,1 ... 3s
Set up menu: >3s
3. Possibility
If no button is pressed for 30 seconds, the menu will be closed automatically.

Error message

1. Flashing display of the actual pressure: measured pressure outside of the adjustment range.
2. Flashing of the display during the programming: A not valid value was entered. (switching point above/below the adjustment range , reset point above/below the adjustment range, reset point above the switching point, analogue output span is smaller than 20% of the adjustment range, Filter more than 2s) the buttons are locked for 3s and the switch takes over the next possible value.

6. Technical data

Configuration	according to the measuring range for over and under pressure
Pressure connection	G 1/4 DIN 3852-E (standard)
Setting	Menu-guided programming using control buttons, adjustable switching points, switchback points, switching function, programmable pressure units: bar, psi
Materials	
• Measuring component	Stainless steel, 0...100 bar ceramic, in each case with NBR seal
• Pressure connection	stainless steel
• Housing	stainless steel plastic display electronics
Load change	> 10 million pressure cycles
Power supply	12... 30 VDC
Power consumption	≤ 50 mA, without load current
Outputs	
• SC400, SC350	2 switch outputs, programmable
• SC410, SC350	1 programmable switch output and 1 analogue output, programmable, scaling 20...100% of final value
Switch outputs	
• Quantity	1 or 2 x switch to N or P potential
• Function	Normally open contact (NO) or normally closed contact (NC), programmable
• Switching current	max. 0,5 A
• Setting	Via display with control buttons
- Switching point	1 to 100% of final value

- Reset point	0...99% of final value (but lower than switching point)
Damping (Firmware option)	0...2000 ms
Delay (Firmware option)	0...99,99 s
• Status indication	2 LED
Analogue output	
• Signal	4 to 20 mA, 3-conductor or 0 to 10 V, 3-conductor
• Load resistance	Current output: < 500 Ω , Voltage output: > 10 k Ω
• Hysteresis	0.3% of final value for ceramic cell, 0.2% of final value for thin film cell
Display	
• Principle	7-segment LED, red, 4 digits, character height 7.6 mm
• Scope	-999 ... 9999
• Accuracy	1% of final value +/- 1 digit
Reproducibility	0.2% of final value
Temperature ranges	
• Bearings	-30...+80°C
• Measuring material	-20...+80°C
• Environmen	-20...+70°C
• Tk	0,3 % / 10K
Electrical connection	Round connector M 12x1; 4-pin
Protection class	IP 65
CE - symbol	Interference emission and interference immunity in acc. with EN 61 326
Electrical protection classes	Pole reversal and overvoltage protection
Weight	Approx. 0,3 kg

Dimensioned drawings

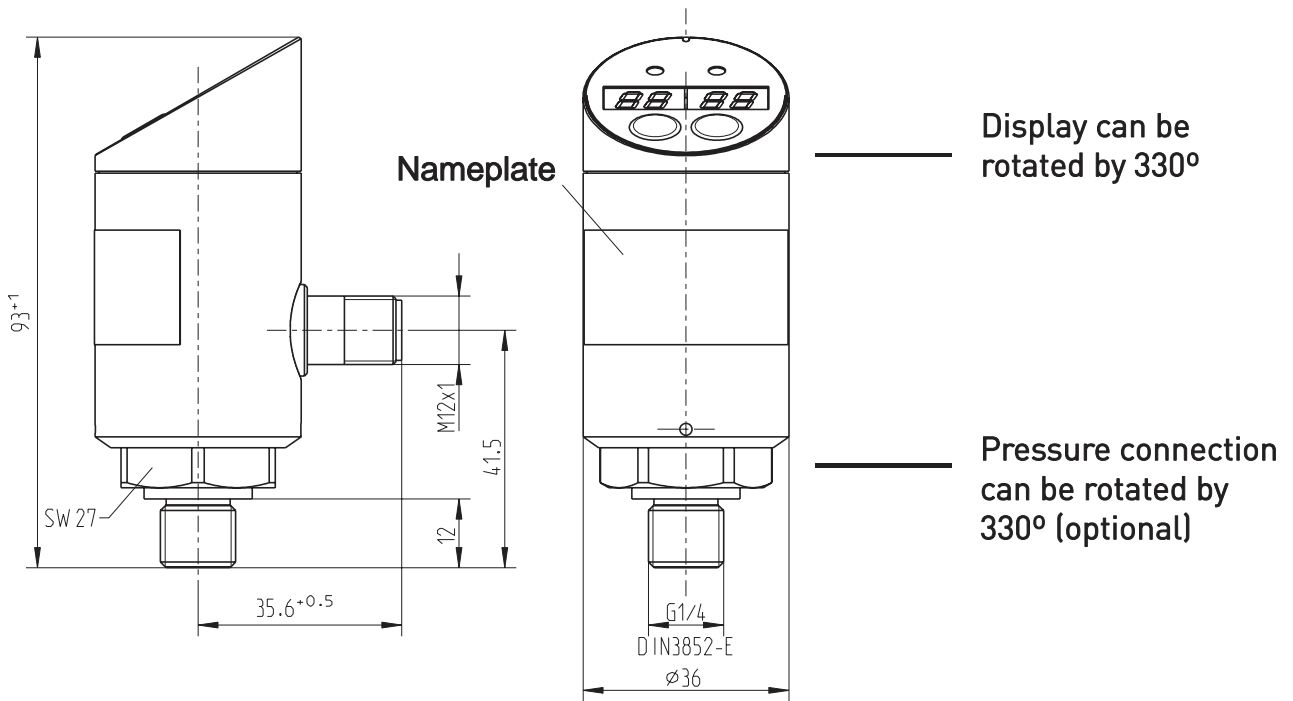

7. CE – conformity

The switch complies with all requirements of EN 61 326 with regard to interference emission and immunity for use in industrial areas. We recommend the use of shielded cables. Installation and cable routing must be carried out correctly in order to maintain the effective protection from electromagnetic interference.

8. Maintenance

The pressure switches that are described in this document are maintenance free. The equipment will also operate in a stable state for long periods, meaning that regular adjustment or the like is not required.

Remove the device as soon as device malfunctions start to occur. The internals cannot be maintained by the customer. Replace the device or return it to Kobold to have it tested.

9. Troubleshooting

No modifications must be made to the equipment. Only **Kobold** is allowed to repair the device.

10. Cleaning

The exterior of the pressure switch can be cleaned using a soft, moistened cloth. Heavy soiling can be removed using a mild cleaning agent.

The switch must not be opened under any circumstances!

Aggressive chemicals or hard scrubbing can damage the surface, particularly the display film.

11. Disposal

The packaging and used parts must be disposed of in accordance with the regulations of the country in which the device is installed.

Declaration of Conformance

We, KOBOLD Messring GmbH, Hofheim-Ts, Germany, declare under our sole responsibility that for the product:

Electronic Pressure Switch Model: PSC

the following EEC guidelines are fulfilled:

IEC 61326 Electrical equipment for measurement, control and laboratory use - EMC requirement

Hofheim, den 28. Jul. 2005



H. Peters
General Manager



M. Wenzel
Proxy Holder