

KOBOLD KAL-L (KAL-8000 Series)

Thermal Air Flow Switch

User Instructions



KOBOLD Instruments Inc. 1801 Parkway View Drive Pittsburgh PA 15205

Phone (412) 788-2830 • Fax (412)-788-4890

Manual-KAL-L_5-12

Table Of Contents

1.0	General	1
2.0	Specifications	1
3.0	Mechanical Installation.....	3
3.1	Installation General	3
3.2	Installation of Units with NPT Thread Connection.....	5
3.3	Installation of Units with HVAC Flange Connection.....	5
4.0	Electrical Connections	5
5.0	Operation	6
5.1	Flow Setpoint Adjustment	6
5.2	Adjustment of the Start-up Time Delay	8
6.0	Maintenance	9
7.0	Need Help with Your KAL-L Flow Switch?	9

List of Diagrams

Diagram 2.1:	Dimensions.....	2
Diagram 3.1:	General Installation	4
Diagram 3.2:	Required Straight Pipe Runs	4
Diagram 4.1:	Electrical Connections.....	5
Diagram 5.1:	Interior Controls Layout for the KAL-L.....	6

List of Tables

Table 2.1:	Model Number Codes	3
------------	--------------------------	---

CAUTION: For safety reasons, please read the cautionary information located at the end of the manual, before attempting installation.

1.0 General

The KAL-L (KAL-8000 Series) Thermal Air Flow Switch uses the proven calorimetric principle to monitor the flow of air or non-hazardous gases. A sensing resistive thermal device (RTD) is heated to a few degrees above the temperature of the flow medium. As the medium flows across the sensing RTD it cools the RTD. The rate of cooling is proportional to flowrate. A second RTD measures medium temperature and the KAL-L electronics uses this measurement to compensate for changes in medium temperatures thus preventing false readings due to medium temperature transients. If the measured flow value drops below the setpoint value, an output relay is activated providing an alarm or control input.

2.0 Specifications

Switching Range:	3.3 to 66 feet/second @ 68°F/14.5 PSIA Restricted span for other pressure and temperature conditions
Accuracy:	±10% of flow rate
Repeatability:	±1% of flow rate
Display	
Flowrate:	8 LED trend indicator
Switchpoint:	Flashing LED in trend indicator
Switch Status:	Dual colored LED RED = Flow below switchpoint GREEN = Flow above switchpoint
Max. Temperature Gradient:	30°K(°C)/Min. @ 25 feet/sec and 190°F
Response Time:	Adjustable 1 to 60 seconds
Warm-up Time:	30 seconds
Max. Pressure:	120 PSIG
Temperature Range	
Process:	-10 to +250°F
Ambient:	+15 to +140°F
Wetted Parts:	Ni-Plated brass
Housing:	Polyamide
Electrical Data	
Power Requirements:	24 VDC/VAC +10%/-15%
Switch Characteristics:	1-SPDT relay Max. 250 VAC/4 A/1000 VA
Electrical Connection	
Standard:	Cable gland
Optional:	1/2" NPT Conduit or M-12 plug
Protection:	NEMA 4/IP 65

Diagram 2.1 Dimensions

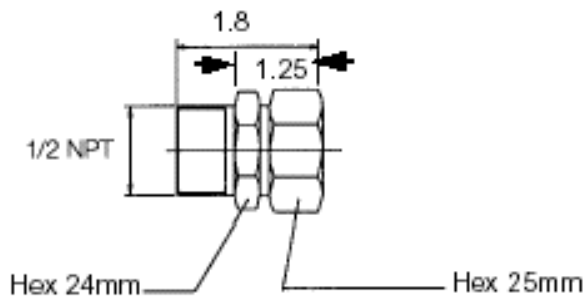
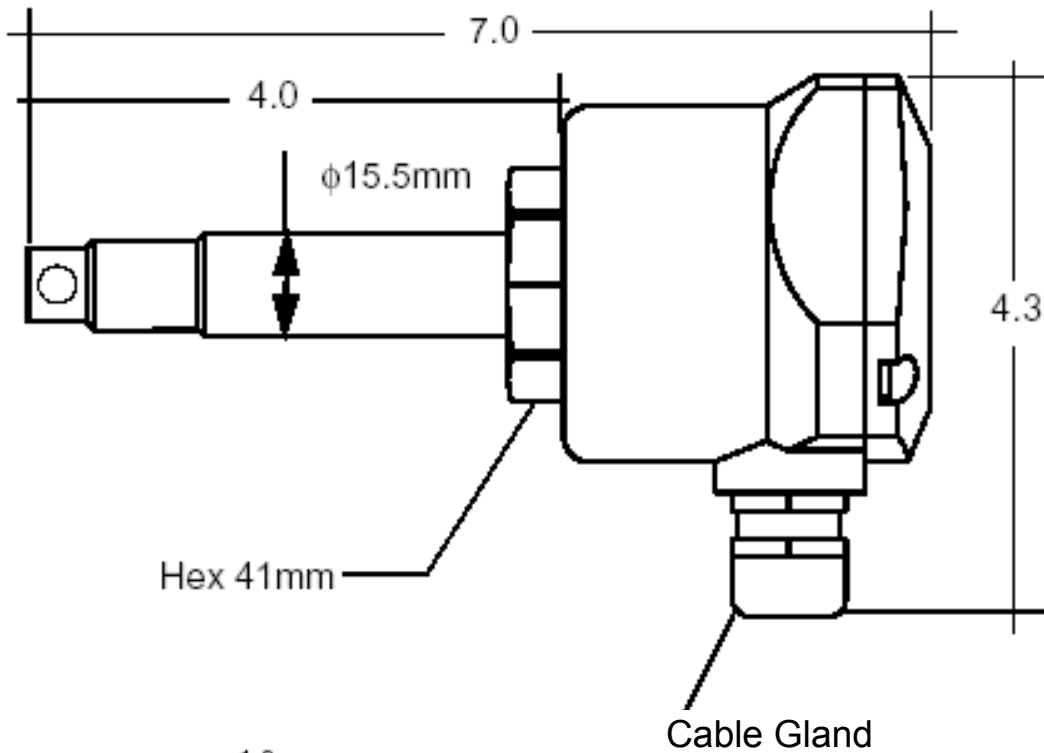

Cable Gland

1/2" NPT
Compression Fitting

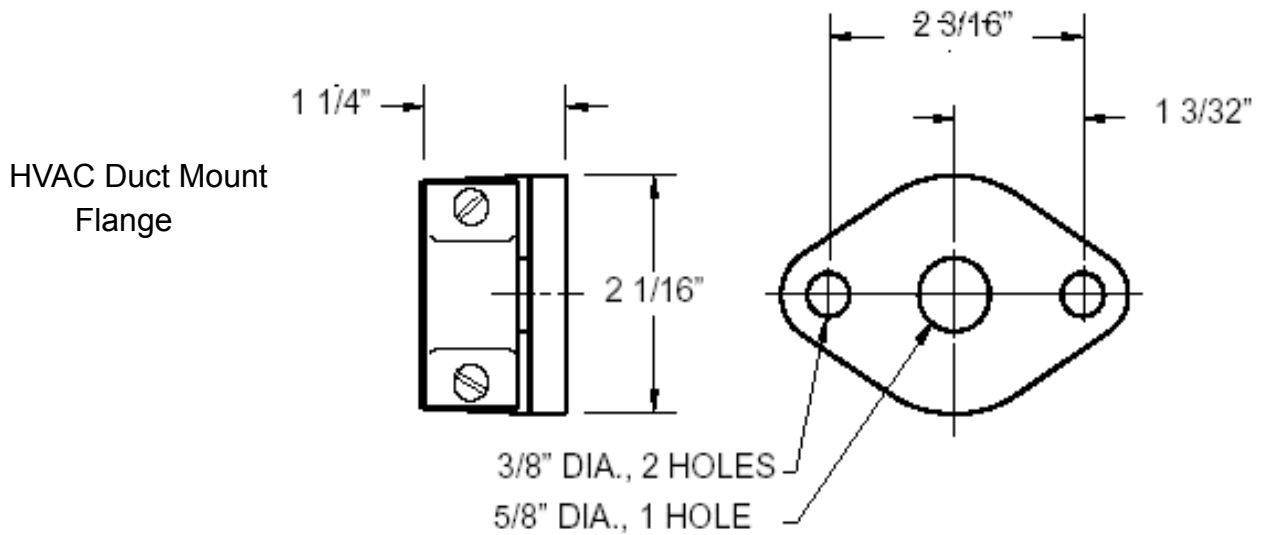

HVAC Duct Mount
Flange

$\frac{3}{8}"$ DIA., 2 HOLES
 $\frac{5}{8}"$ DIA., 1 HOLE

All dimensions in inches
Unless otherwise noted

Table 2.1 Model Number Codes

Model Code	Description
KAL-8115	15mm smooth bore probe with 1/2" NPT compression fitting
KAL-8115FL	15mm diameter probe with clamping flange per DIN 43 743
Options	
Option Suffix	Description
-M12	NEMA 4 electrical plug connector
-C	1/2" NPT conduit connection

3.0 Mechanical Installation

CAUTION

Prior to mechanical installation, ensure that the process flow velocity to be monitored is within the switching range of the device. Also ensure that system temperature and pressure are within the limit of the device. See Section 2.0 "Specifications".

3.1 Installation General

The following general installation instructions and precautions apply to all KAL-8000 series installations:

- 3.1.1 The probe tip **must be inserted a minimum of 3/8" beyond the inside diameter of the pipe or duct into which it is to be installed.** Best results are obtained if the probe is inserted into the pipe or duct 1/2" or greater.
- 3.1.2 In order to ensure that the sensing elements are facing directly into the flow stream, a notch has been placed on the probe hex nut to aid in alignment. For optimal results, the probe should be installed so that the notch is aligned directly over the centerline of the pipe or duct.
- 3.1.3 In order to ensure a uniform flow profile across the probe tip, install the probe to allow for 10 pipe diameters of straight run piping upstream and 5 downstream. This piping should be free of tees, elbows, bends, valves, dampers or any other such appurtenances.
- 3.1.4 The probe should not be installed in the lower hemisphere of the pipe or duct. Liquid and debris which collect in the lower portion of the pipe will cause the probe to function erratically if they come in contact with the probe.

Diagram 3.1 General Installation

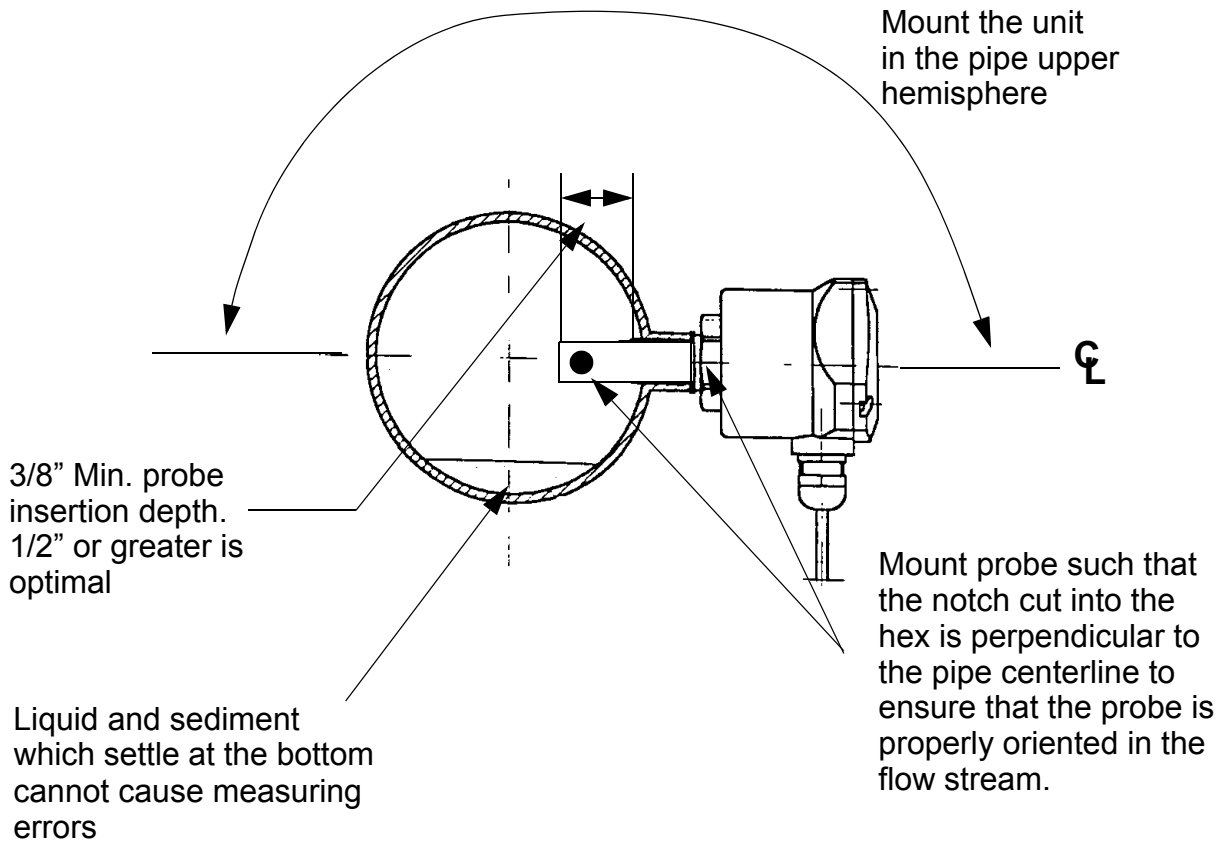
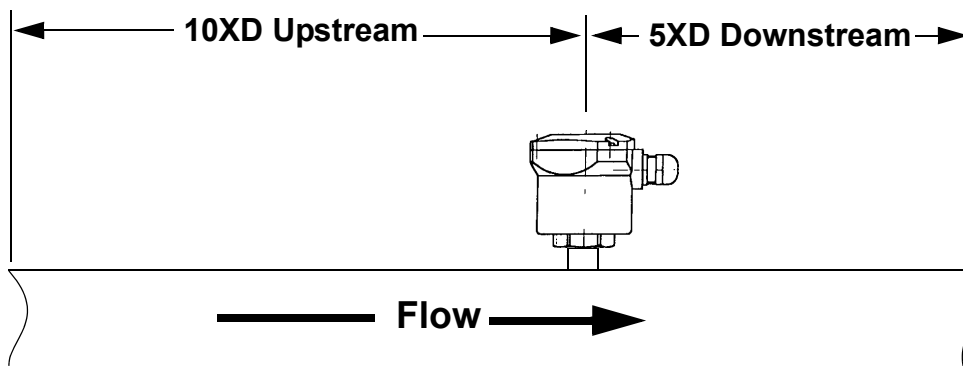

Diagram 3.2 Required Straight Pipe Runs



- 3.2.1 Units with NPT threaded connections are best suited for round pipes or ducts in which systems are under pressure. The NPT connection makes a leaktight seal to 120 PSIG.
- 3.2.2 The threaded connection should be installed into a pipe via a 1/2" weld coupling or a pipe tee with 1/2" connection. If a bushing is used to reduce a larger fitting size to 1/2", ensure that the probe insertion requirements are met. See Section 3.1 "Installation General".
- 3.2.3 Ensure that a thread sealant such as PTFE tape is used to seal the threads.

3.3 Installation of Units with HVAC Flange Connection

- 3.3.1 Units with flanged connections are best suited for square ducts in HVAC applications where adding an NPT connection is impractical.
- 3.3.2 Prior to installing the flange, the flange face which contacts the surface of the HVAC duct should be sealed using a field manufactured gasket or RTV compound. This will minimize leakage at the flange face.

4.0 Electrical Connections

- 4.0.1 All electrical connections are made at the terminal blocks inside the electronics enclosure of the KAL-L.
- 4.0.2 The KAL-L can operate using a power supply of 24 VAC or DC. **When DC voltage is used, the input supply is non-polarized. The polarity of the DC input voltage does not matter and can be wired in either direction without affecting the operation of the unit.**

Diagram 4.1 Electrical Connections

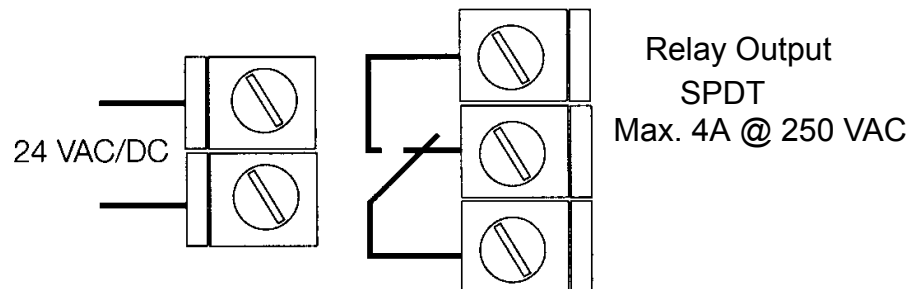

5.0 Operation

Diagram 5.1 Interior Controls Layout for the KAL-L

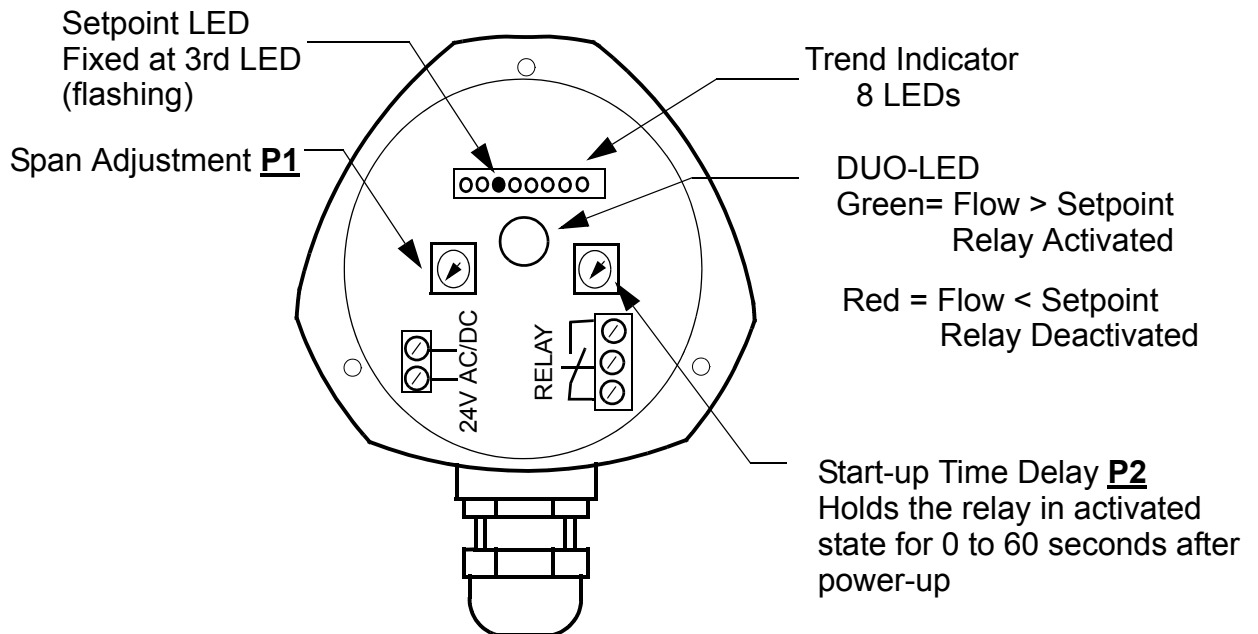

5.1 Flow Setpoint Adjustment

The section describes the procedures for adjustment of the flow setpoint for three scenarios:

- Adjustment of precise setpoint on falling flow.
- Adjustment of precise setpoint on rising flow.
- Setup for flow/no flow detection.

5.1.1 Flow Setpoint Adjustment - General

The flow switch point on the KAL-L is fixed at 50% of its span. Because of the trend indicator's non-linear response, this corresponds to the third LED on the indicator bar. The third LED is wired to flash permanently to allow users to judge the location of the flow setpoint relative to system flow.

The flow switch point is set by adjusting the span potentiometer P1. Doing this increases or decreases the span of the trend indicator thereby changing the point at which the KAL-L switches. The next three sections describe how to set the KAL-L switchpoint in specific situations

5.1.2 Adjustment of Precise Setpoint on Falling Flow

To adjust the KAL-L for a precise switchpoint on falling flow, refer to Diagram 5.1 on page 6 and proceed as follows:

- 5.1.2.1 With power connected to the KAL-L, adjust the span potentiometer **P1** clockwise to its right hand stop. Turn time delay potentiometer **P2** counter-clockwise to its far lefthand stop.
- 5.1.2.2 Initiate system flow and adjust it to the desired switchpoint flow rate. Note that at this time the DUO LED should be green. If it is red your desired flowrate is below the measuring capability of the KAL-L.
- 5.1.2.3 Slowly turn **P1** counter-clockwise. You will note that the LEDs on the trend indicator will extinguish sequentially as the span is reduced. Continue turning **P1** counter-clockwise until the trend indicator span is reduced to the third LED (which is flashing). At this point, the DUO-LED turns red and the relay switches over. The KAL-L is now adjusted at the desired setpoint.
- 5.1.2.4 Adjust system flow to normal.

5.1.3 Adjustment of Precise Setpoint on Rising Flow

To adjust the KAL-L for a precise switchpoint on rising flow, refer to Diagram 5.1 on page 6 and proceed as follows:

- 5.1.3.1 With power connected to the KAL-L, adjust the span potentiometer **P1** counter-clockwise to its left hand stop. Turn time delay potentiometer **P2** counter-clockwise to its far lefthand stop.
- 5.1.3.2 Initiate system flow and adjust it to the desired switchpoint flow rate.
- 5.1.3.3 Slowly turn **P1** clockwise. You will note that the LEDs on the trend indicator will light sequentially as the span is increased from zero. Continue turning **P1** clockwise until the trend indicator span is increased to the third LED (which is flashing). At this point, the DUO-LED turns green and the relay switches over. The KAL-L is now adjusted at the desired setpoint.
- 5.1.3.4 Adjust system flow to its normal value.

5.1.4 Setup of the KAL for Flow/No-flow Detection

Alternatively, the KAL-L can be quickly set-up to switch on a loss of flow. Using this procedure does not yield a precise switchpoint but is generally acceptable for flow/no-flow detection. When set up in this manner, the KAL-L will switch when approximately a 50% reduction from normal flow occurs. To set the KAL-L for flow/no-flow detection, refer to Diagram 5.1 and proceed as follows:

- 5.1.4.1 With power connected to the KAL-L, adjust the span potentiometer **P1** counter-clockwise to its left hand stop. Turn time delay potentiometer **P2** counter-clockwise to its far lefthand stop.
- 5.1.4.2 Initiate system flow. Ensure that system flow rate is at normal operating value.
- 5.1.4.3 Slowly turn **P1** clockwise. You will note that the LEDs on the trend indicator will light sequentially as the span is increased from zero. Continue turning **P1** clockwise just until all 8 trend indicator LEDs are lit. As the trend indicator span is adjusted past the third LED (which is flashing) note that the DUO LED changes from red to green and the relay switches over.
- 5.1.4.4 The KAL-L is now adjusted for flow/no flow detection. The switch point will occur on a flow rate reduction of approximately 50% from normal operating value.

5.2 Adjustment of the Start-up Time Delay

The KAL-L has a start-up time delay feature which holds the output relay in the activated state and disables flow monitoring for a period of up to 60 seconds after power-up of the KAL-L. This feature is designed to prevent nuisance alarms during system start-up and until steady state flow conditions are achieved.

To adjust the start-up time delay, refer to Diagram 5.1 on page 6 and proceed as follows:

- 5.2.1 Potentiometer **P2** adjusts the start-up time delay. Turning **P2** counter-clockwise to its far left hand stop adjusts the time delay to zero. Turning **P2** clockwise increases the time delay to a maximum possible of 60 seconds at the far right hand stop. The time delay adjustment is approximately linear between the left and right hand stops.

6.0 Maintenance

The KAL-L is an electronic device which uses no moving parts. This design ensures reliable operation and long service life. Dirt and debris which can build up on the sensing probe over time will result in degraded performance. For this reason we strongly recommend that the proper filtration be installed in the system. It is also recommended that the KAL-L be occasionally removed from the system and its measuring probe inspected for dirt buildup and cleaned as needed. The frequency of this cleaning will vary depending on the cleanliness of the system.

7.0 Need Help with Your KAL-L Flow Switch?

Contact one of our friendly engineers at 412-788-2830.

CAUTION

PLEASE READ THE FOLLOWING WARNINGS BEFORE ATTEMPTING
INSTALLATION OF YOUR NEW DEVICE. FAILURE TO HEED THE
INFORMATION HEREIN MAY RESULT IN EQUIPMENT FAILURE AND
POSSIBLE SUBSEQUENT PERSONAL INJURY.

- **User's Responsibility for Safety:** KOBOLD manufactures a wide range of process sensors and technologies. While each of these technologies are designed to operate in a wide variety of applications, it is the user's responsibility to select a technology that is appropriate for the application, to install it per these installation instructions, to perform tests of the installed system, and to maintain all components. The failure to do so could result in property damage or serious injury.
- **Proper Installation and Handling:** Use a proper sealant with all installations. Never overtighten the unit within the fitting. **Never use the housing to thread the unit into its fitting.** Always use only an appropriate sized wrench on the hex portion of the probe. Always check for leaks prior to system start-up.
- **Wiring and Electrical:** A supply voltage of 24 Volts AC or DC +10%/-15% is used to power the KAL-L. The sensor systems should never exceed this rating. Electrical wiring of the sensor should be performed in accordance with all applicable national, state, and local codes.
- **Temperature and Pressure:** The KAL-K is designed for use in application temperatures from -10 to 250°F, and for use at pressures up to 115 PSIG. Operation outside these limitations will cause damage to the unit and possible personal injury.
- **Material Compatibility:** The KAL-K sensor probe is made of nickel plated brass. The housing is polycarbonate. Check your model number with the wetted materials specification in Section 2.0, "Specifications", on page 1 of this manual. Make sure that the model which you have selected is chemically compatible with the application environment. While the switch housing is liquid resistant when installed properly, it is not designed to be immersed. It should be mounted in such a way that it does not normally come into contact with liquid.
- **Flammable, Explosive and Hazardous Applications:** The KAL-L is not an explosion-proof or intrinsically safe design. It should not be used in hazardous areas where risk of explosion exists.
- **Make a Fail-safe System:** Design a fail-safe system that accommodates the possibility of switch or power failure as well as operator error. In critical applications, KOBOLD recommends the use of redundant backup systems and alarms in addition to the primary system.

