



KOBOLD Instruments Inc.
 1801 Parkway View Drive
 Pittsburgh, PA 15205
 PH: 412-788-2830
 FAX: 412-788-4890
 www.koboldusa.com

Series DRS
Turbine Flow Sensor

Precautions

- **User's Responsibility for Safety:** KOBOLD manufactures a wide range of process sensors and technologies. While each of these technologies are designed to operate in a wide variety of applications, it is the user's responsibility to select a technology that is appropriate for the application, to install it properly, to perform tests of the installed system, and to maintain all components. The failure to do so could result in property damage or serious injury.
- **Proper Installation and Handling:** Use a proper sealant with all installations. Never overtighten the sensor within its fittings. Always check for leaks prior to system start-up.
- **Wiring and Electrical:** Because this is an electrically operated device, only properly trained personnel should install and maintain this product. Be sure that the power supplied to the flow sensor is appropriate for the electronics version supplied. Electrical wiring of the sensor should be performed in accordance with all applicable national, state and local codes.
- **Temperature and Pressure:** The DRS is designed for use in application temperatures from -4°F to 176°F. Operation outside these limitations will cause damage to the unit.
- **Material Compatibility:** The wetted parts for the various body materials are stated below. Make sure that the DRS is chemically compatible with the application liquids. While the sensor's outer housing is liquid resistant when installed properly, it is not designed to be immersed. It should be mounted in such a way that it does not normally come into contact with fluid.
- **Flammable, Explosive and Hazardous Applications:** The DRS is not an explosion-proof design. It should not be used in applications where an explosion-proof design is required.
- **Make a Fail-Safe System:** Design a fail-safe system that accommodates the possibility of sensor or power failure. In critical applications, KOBOLD recommends the use of redundant backup systems and alarms in addition to the primary system.

Specifications

Flow Range: 0.6 to 10.5 GPM (2-40 LPM) Water

Accuracy: ±1.5% of full scale

Linearity: ±0.5% of full scale

Wetted Parts

- Plastic Body: PPO, PEI, NBR, Sapphire, 316 SS
- Stainless Steel Body: 304 SS, 316 SS, PEI, FKM, Sapphire
- Brass Body: Brass, 316 SS, PEI, NBR, Sapphire

Fittings: 1/2" NPT Female, 3/4" NPT Male,

Max. Pressure: 230 PSIG

Temperature Range: -4°F to +176°F

Electrical Protection (all versions): IP 65

Output K0000

(OEM Version): NPN open collector pulse output, 6-16 VDC 10 mA max., 5 Ft. PVC cable connection

Output F300 & F500

PNP Pulse Output: PNP open collector, 10 mA max. Load, power = 24 VDC ± 20%, 20 mA max.

Electrical Connection: F300 = 4 pin micro-DC plug,
 F500 = 6 Ft. PVC cable,

Nominal Output Freq: 320 Hz ± 12 Hz @ 10.5 GPM (40 LPM)

Electrical (continued)

Output L342: 4-20 mA, 2-wire, Rmax < 500 ohms, power= 24 VDC

Electrical Connector = 4 pin micro-DC plug, male

Output L343: 4-20 mA, 3-wire, Rmax < 500 ohms, power= 24 VDC

Electrical Connector = 4 pin micro-DC plug, male

Output L442: 4-20 mA, 2-wire, Rmax < 500 ohms, power= 24 VDC

Electrical Connector = DIN 43650 (Hirschmann) plug

Output Type C34P & C30R

Compact Electronics: 4-20 mA + 1 PNP switch or 2 PNP switches depending on model code

Power Supply: 24 VDC ±20%, 80 mA max.

Analog Output: 4-20 mA, 3-wire, Rmax < 500 ohm

Switch Type: PNP open collector, 24 VDC, 300 mA max.

Electrical Connection: 5 pin micro-DC plug, male

Electrical Connection for Output C30R, C34P

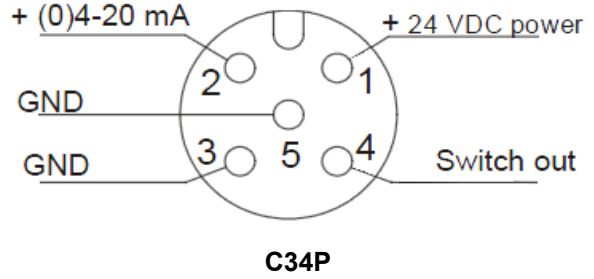
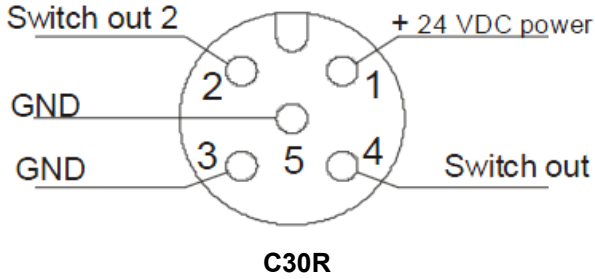

Micro-DC Cable Color Codes: Brown=Pin 1; White=Pin 2; Blue=Pin 3; Black=Pin 4; Gray=Pin 5

Electrical Connection for Output F300, F500, L343 (3-wire transmitters without option P)

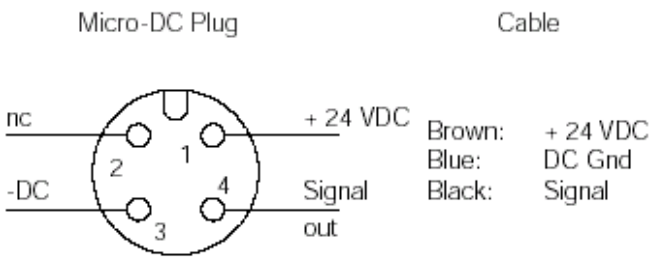

Electrical Connection for Output Z340

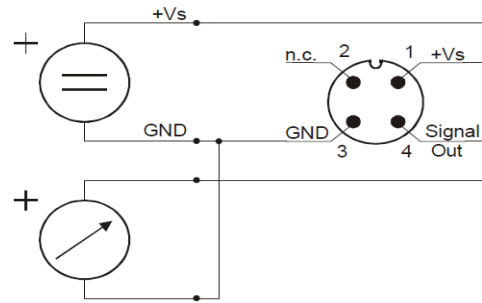

Caution! In case current output is not needed, PIN 4 (Signal OUT) is to be permanently connected with Ground (GND)(short circuit jumper).

Electrical Connection for Output L342 (2-wire 4-20 mA)

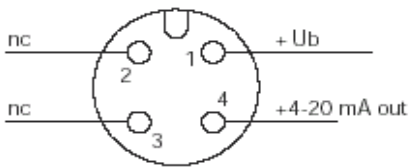

Electrical Connection for Output K0000 (NPN OEM)

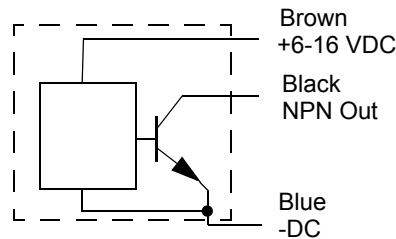

Electrical Connection for Output L442 (2-wire 4-20 mA)

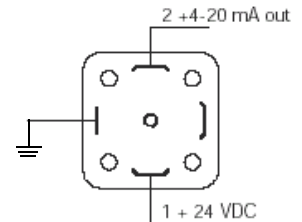

Mechanical Installation

Piping Preparation: Piping should be rigidly supported at both the inlet and outlet of the sensor to prevent potential damage due to excessive stress on the sensor fittings. In order to ensure that the fluid flow profile is fully developed and symmetrical, a minimum straight piping run of 20 pipe diameters upstream and 10 diameters downstream of the sensor are required. The straight runs should be free of tees, elbows, valves, reducers and other disturbances.

Pumps: All pumps cause pulsations in the fluid. Centrifugal pumps cause the least amount of pulsations in the fluid and positive displacement or reciprocating pumps cause the most. In order to minimize the effect of these pulsations on sensor accuracy, the sensor should be located as far away from the pump as possible. A pulsation dampener or accumulator may be used to dampen pulsations if required. If the fluid pulsations cannot be reduced to an acceptable level, a field calibration to determine the new K-factor for the sensor installed in a pulsating system may be required.

Viscosity: All flow range and calibration data provided with this sensor are for water. All turbine type transducers are affected by viscosity. Higher viscosities tend to make the turbine wheel turn slower for a given flow rate. This results in a lower K-factor for the sensor when it is used with a viscous media (i.e. viscosity > 10 cSt.) and the calibration data provided for water flow is no longer valid. If the sensor is to be used with viscous media, a field calibration is required to determine the new K-factor for the sensor.

Field calibration: For frequency output versions, a simple field calibration can be performed to determine the new K-factor for the sensor when it is to be used in a manner in which the above specified calibration information does not apply (i.e. use with viscous or pulsating media, insufficient straight run etc.). With the sensor installed in the system, dispense a known quantity of the fluid to be measured while using a pulse counter to count the number of pulses generated by the sensor during the dispense. This information can be used to determine the new K-factor specific to your system and fluid.