



## Oval Wheel Flowmeter

for low and high viscous liquids



measuring  
•  
monitoring  
•  
analysing

DOE



- Measuring range:  
0.5 ... 36 l/h and 1 ... 40 l/min
- Viscosity range: up to 1000 cP
- Accuracy:  $\pm 1\%$  of reading
- Material: stainless steel
- $p_{\max}$ : 64 bar;  $t_{\max}$ : 80 °C
- Pulse output



Order from: **C A Briggs Company**  
622 Mary Street; Suite 101; Warminster, PA 18974  
Phone: 267-673-8117 - Fax: 267-673-8118  
[Sales@cabriggs.com](mailto:Sales@cabriggs.com) - [www.cabriggs.com](http://www.cabriggs.com)

KOBOLD Messring GmbH  
Nordring 22-24  
D-65719 Hofheim/Ts.

S4

### Principle of Operation

Oval gear flowmeters are categorised as positive displacement flow technology. When liquid flows through this type of positive displacement flowmeter, two oval geared rotors measure a constant volume per rotation within a precisely machined measuring chamber. With each rotation, a constant volume of liquid is measured. The rotation of the oval gears is sensed via magnets embedded within the rotors. These magnets transmit a high resolution pulse output. The output signal can be processed externally via a remote display controller or PLC or via a variety of output/display options available as accessories attached to the flowmeters.

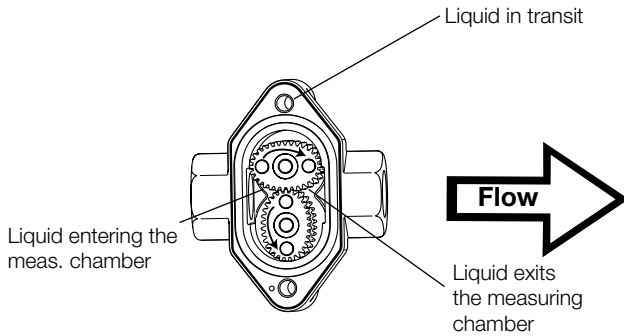

The positive displacement flow technology allows for precise flow measurement of most clean liquids regardless of the media conductivity. Other liquid properties also have a minimal effect on the performance of this type of meter. Flow profile conditioning is not required as with alternative flow technology options making oval gear installations simple to install in tight spaces and at an economical price.

### Areas of Application

For all viscous, non abrasive clean liquids like:

- Petroleum
- Grease
- Pastes
- Oil
- Fuels
- Chemicals
- Ink etc.
- Diesel
- Fuel consumption measurements, e.g. small aeroplanes, motor boats, mobile power generators

Stainless steel flowmeters are suited to most products and chemicals and aluminium meters are suitable for fuels, fuel oils & lubricating liquids. Due to an optional measurement of temperature using PT100 even high accuracy fuel consumption measurements are possible.

**Note:** This is an OEM (Original Equipment Manufacture) device.

### Technical Details

#### Material

DOE-8

- Body: stainless steel 1.4404
- Oval wheels: PEEK for x04, x05, x10, x15  
PPS for x20
- Axes: stainless steel 1.4404, encapsulated magnets
- O-rings: medium temperature  
FKM/NBR: -20... +80 °C
- Magnet encapsulation: DOE-x04 ... DOE-x10 PEEK  
DOE-x15 ... DOE-x20 st. st. 1.4404

#### Accuracy

- (under reference conditions\*):
  - ±3 % of reading 0,5 - 3,6 l/h (DOE-x04)
  - ±1 % of reading 3,6 - 36 l/h (DOE-x04)
  - ±1 % of reading (DOE-x05 ... DOE-x20)

Repeatability: typ. ± 0.03 %

Protection class: IP65

Medium temp.: -20 °C ... +80 °C

Max. pressure: 64 bar

Ambient temp.: -20 °C ... +80 °C

Electrical connection: valve plug EN175301-803 form A or 2 m cable UL/cUL 6xAWG20

\* Reference conditions: x04, x05 (calibration oil 10 cSt, 20 °C, 5 bar)  
x10 ... x20 (calibration oil 4,6 cSt, 25 °C, 1 bar)  
Accuracy is valid for given viscosities and higher

#### Recommended Filter (e.g. model MFR-DO...)

DOE-x04 ... DOE-x15 < 75 µm micron (200 mesh)

DOE-x20 < 150 µm micron (100 mesh)



## Pulse Output

### Reed switch pulse output (... H0)

The reed switch output is a two wire normally open SPST voltage free contact.

**Note:** when using the reed switch output the liquid temperature must not change at a rate greater than 10°C per minute.

Average switching life of reed contact (MTTF):

At max. load 100 V/10 mA  $5 \times 10^5$  switching cycles

At load <5 V/10 mA  $5 \times 10^8$  switching cycles

**Recommended load:**  $\leq 10$  V/10 mA

### Hall sensor pulse output (... H0/T0)

In these electronics options, a Hall Effect sensor used. The electrical connection is provided in 3-wire version. The output is switched to +Vs via pull up resistor. The external supply voltage is 5...24 V<sub>DC</sub>. The high signal is approximately equal to the supply voltage +Vs and the low signal is approximately 0 V.

The electrical load will be connected to the supply voltage.

Maximum output current (current sink): 10 mA (not short circuit protected).

In addition to Hall sensor, the option H0 is equipped with a Reed switch.

### Hall sensor pulse output (... B0/BP)

See options H0/T0, however with bipolar sensors and alternating polarised magnets. This option is used for pulsating flows, but it is not equipped with Reed switch and has halved K-factor as compared to H0/T0. With option »BP« an additional temperature measurement (Pt100) is possible.

## Output Pulse Resolution

Model	Measuring range [l/min]	Pulse/Litre		
		Reed switch H0	Hall sensor T0/H0	Hall sensor B0/BP
DOE-x04	0.5 - 36 l/h	2670	2670	-
DOE-x05	0.5 - 36 l/h	2670	2670	-
DOE-x10	2 - 100 l/h	1054	1054	-
DOE-x15	15 - 550 l/h	355	710	355
DOE-x20	1 - 40	82	163	82

The values in above mentioned table are only approximate guidelines. The actual value for pulse rate can deviate from the values in this table and is mentioned in calibration certificate delivered with the flowmeter.



Pressure Drop Curves vs Viscosity

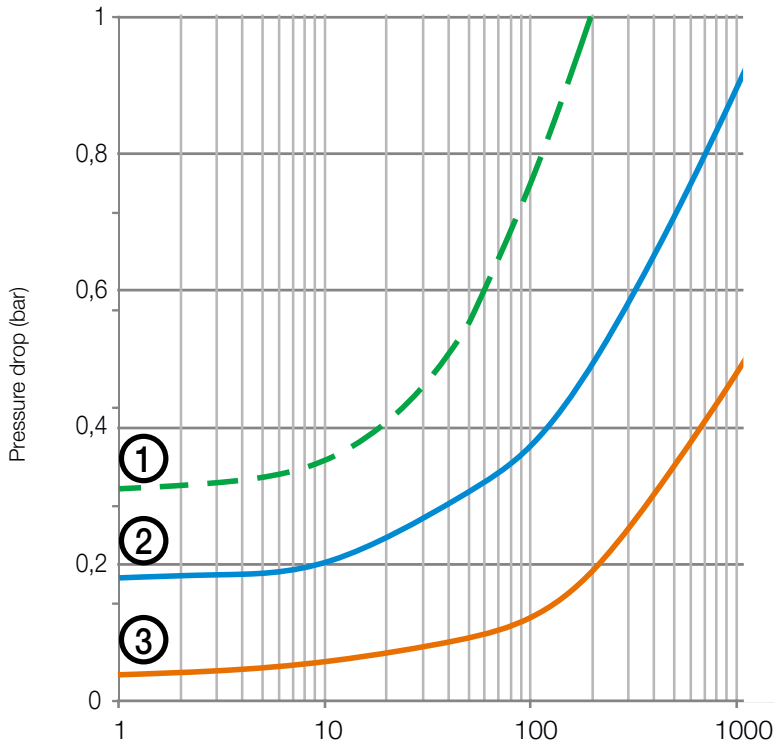

- ① Standard rotors 100 % of full scale
- ② Standard rotors 50 % of full scale
- ③ Standard rotors 25 % of full scale

Order Details (Example: DOE-8 10H R2 1 T0 D 0)

Model	Material housing/rotor	Measuring range	Connection	Gaskets	Electronics	Cable exit/entry	Options
DOE-	8 <sup>2)</sup> = stainl.steel/ PEEK	04H = 0.5-36 l/h 04G = 0.14-9.5 GPH	R1 = G 1/8 N1 = 1/8" NPT	1 = FKM 4 = NBR	<b>T0</b> = pulse output (Hall sensor, NPN, Open Collector), calibrated <b>B0<sup>3)</sup></b> = pulse output (Hall sensor bipolar, NPN, Open Collector) for pulsating flow, calibrated <b>BP<sup>1)3)</sup></b> = pulse output (Hall sensor bipolar, NPN, Open Collector) for pulsating flow, Pt100 (3-wire), calibrated <b>H0<sup>5)</sup></b> = pulse output (Hall sensor, NPN, Open Collector) + Reed switch, calibrated	<b>D</b> = switch acc. EN 175301-803 form A <b>K<sup>4)</sup></b> = 2 m cable	<b>0</b> = without <b>Y</b> = special-option, (specify in clear text)
		10H = 2-100 l/h 10G = 0.5-26.5 GPH	R2 = G 1/4 N2 = 1/4" NPT				
		15H = 15-550 l/h 15G = 4-145 GPH	R3 = G 3/8 N3 = 3/8" NPT				
		20H = 1-40 l/min 20G = 16-634 GPH	R4 = G 1/2 N4 = 1/2" NPT				

1) Only in combination with cable connection »K«  
 2) Stainless steel/PPS for measuring range »20«  
 3) Not for measuring ranges »04«, »05« and »10«  
 4) Only for option »BP«  
 5) Only for range »10«

**Note:** Minimum order quantity for each PO = 25 pieces (Different models may be combined)

### Fuel consumption of Diesel engines

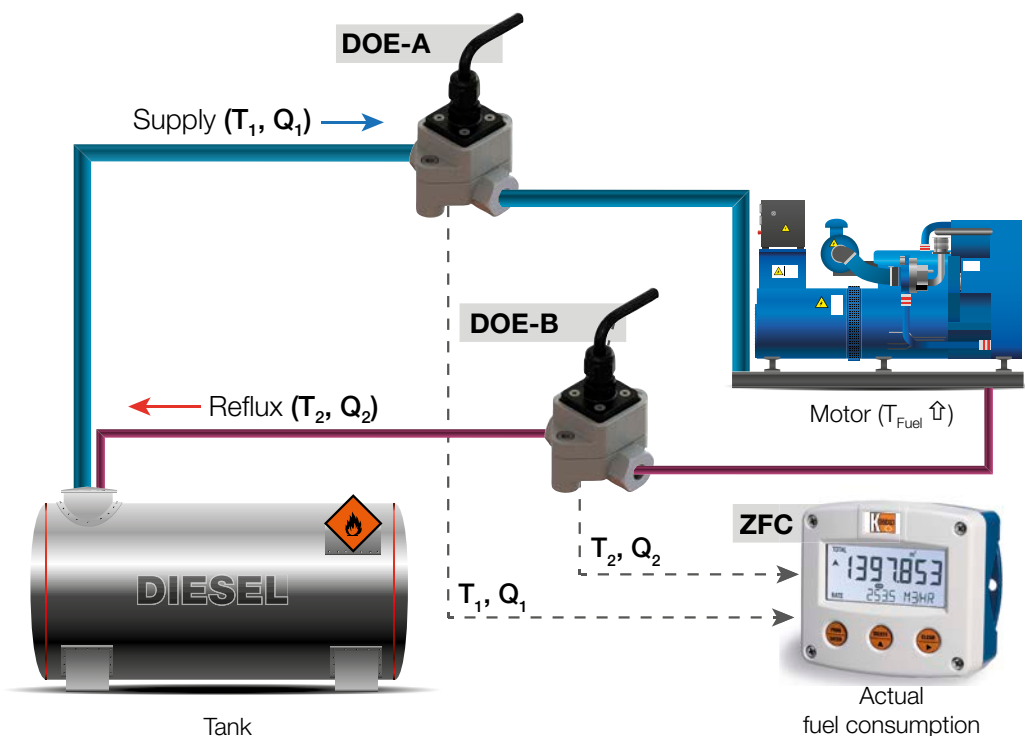

#### High-precision Fuel Consumption Measurement, thanks to Temperature Compensation

The low-pressure fuel system of most diesel engine installations is designed as a ring circuit to ensure that the engine is supplied with sufficient fuel as rapid load changes take place. The friction of injection pump piston, the radiation heat of engine and the kinetic energy of flowing fuel creates a temperature difference between the cooler flow and the hot returning flow. Temperature differences of 60 °C are not uncommon. With increasing temperature, the fuel expands increasingly and as a result, its volume changes. If this effect is not compensated, the measured value is incorrect.

This effect (not compensated) has a significant impact on the measurement accuracy and should not be neglected. The adjacent table shows the density decrease in the fuel rate per 20 °C temperature difference. In a light fuel oil system, the density of the fuel oil is reduced, for example, a temperature increase of 40 °C reduces the density by about 3.1%. As a result according to the Gaussian error propagation, a total system error of 8.5% occurs. In a heavy fuel system, a temperature difference of 20 °C results in a density difference of 1.6% and a total error of 5%.

By measuring fuel consumption along with a temperature compensation (which measures the temperature in the

ongoing flow and returning flow) ensures that the ongoing and returning volumes are measured with respect to the same temperature and thus remain comparable.

Our flow computer model ZFC has been developed to calculate corrected differential liquid volume at normal conditions for generic products.

#### Density table of fuels

(DIN 51757, method B)

T	$\rho_{LFO}(T)$	$\rho_{HFO}(T)$	Relative error LFO	Relative error HFO
[°C]	[kg/m <sup>3</sup> ]	[kg/m <sup>3</sup> ]	[%]	[%]
20	906.5	976.3	0.0	3.2
40	892.5	961.3	-1.5	1.6
60	878.6	946.2	-3.1	0.0
80	864.4	930.9	-4.6	-1.6
100	850.2	915.6	-6.2	-3.2
120	835.9	900.2	-7.8	-4.9

**Electrical Connection**  
DOE- ...H0/T0/B0

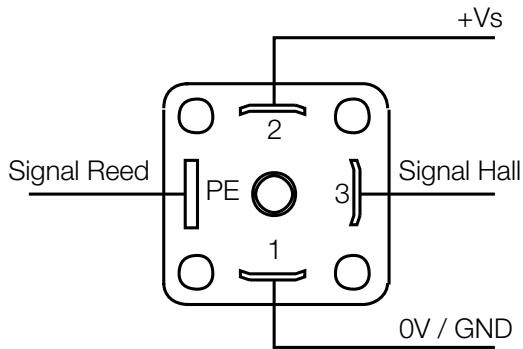

DOE- ...BP

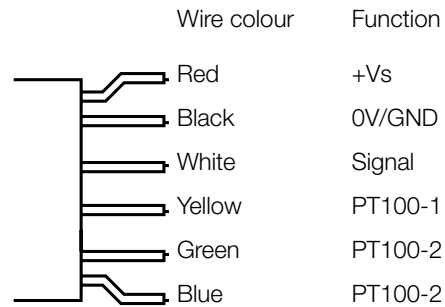

**Technical Details MFR-DO (Version Stainless Steel)**

- Design: two-part screwed body
- Connections: female G ¼ ... G ½  
DIN ISO 228 T1
- Pressure rating: PN 40
- Temperature range: -30 °C ... +160 °C
- Mesh size: 200 mesh / 75 µm for G ¼, G ¾  
100 mesh / 150 µm for G ½
- Mounting position: cover toward bottom,  
note specified direction of flow

**Materials**

- Housing (1): stainless steel 1.4408, EN1503-1
- Cover (2): stainless steel 1.4408, EN1503-1
- Mesh (4): stainless steel 316
- Cap (9): stainless steel 1.4408, EN1503-1
- Seal (11): PTFE
- O-ring (31): FPM

**MFR-DO**

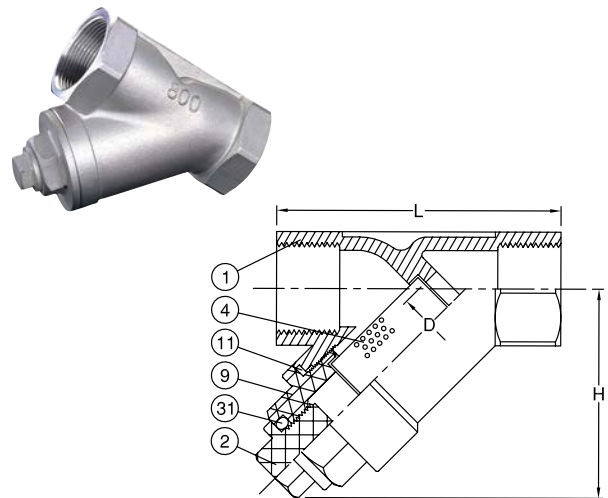

**Dimensions and Order Details**

**MFR-DO version stainless steel**  
(Example: MFR-DOR15)

Order-Nr.	Size		L	H	D
			[mm]	[mm]	[mm]
MFR-DOR08	DN08	G ¼	65.0	51.0	10.0
MFR-DOR10	DN10	G ¾	65.0	51.0	12.0
MFR-DOR15	DN15	G ½	65.0	51.0	15.0

**Dimensions [mm]**

DOE-x04...DOE-x10

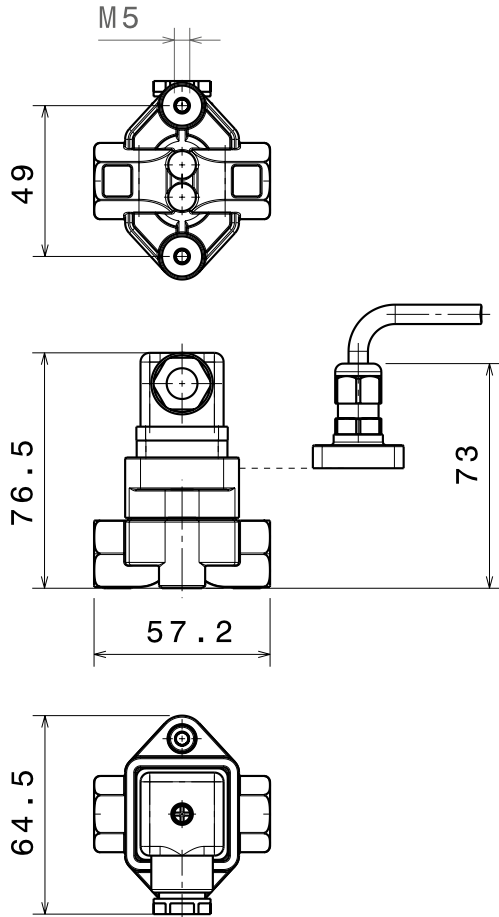

DOE-x15

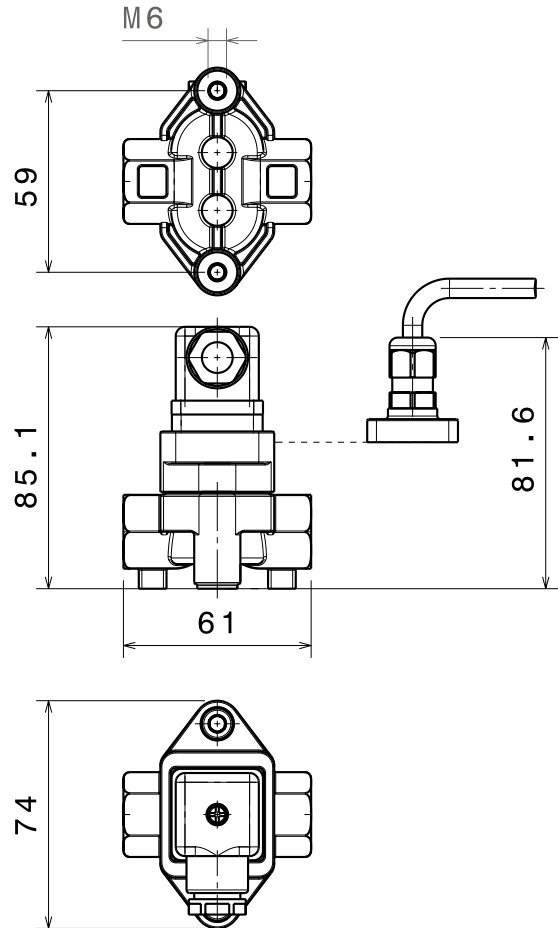



**Dimensions** [mm] (continued)  
DOE-x20

