

Float Type Level Switches Installation and Maintenance

APPENDIX X

Orientation

A standard NPT female boss in tank top, bottom or side is all that is required for rapid installation. Units operate normally in any attitude — from the vertical to a 30° inclination — with lead wires up or down. Standard IPS pipe extends units to any intermediate level in the tank. Figure 1.

Accuracy and Repeatability

The accuracy of many GEMS level switches is $\pm 1/8"$ (3.2 mm) of true liquid level. In order to assure the proper accuracy for your liquid, please specify the specific gravity of the media. GEMS will automatically calibrate for the submergence of the float, based on this specific gravity information. Furthermore, accuracy may be enhanced by specifying whether the circuit condition should be measured on decreasing or increasing liquid level. The repeatability of the actuation point is approximately 1/32 inch (.79 mm).

Moisture Protection

When moisture exists in conduit and extension pipes, the potential for this moisture to wick down the wire leads and into the switch assembly exists. Should this happen, the switch may fail to close due to a high resistance path through the moisture.

There are several means that can be used to prevent this from happening.

1. Pitch conduit away from the level switch when possible so that condensation will drip away from the level switch assembly. Figure 2.
2. When a vertical run of extension pipe is used to extend a level switch down from the top of the tank, a non-conductive silicone oil should be used to fill the vertical run. Alternatively, an appropriate potting may be used to fill the vertical run to occupy the space in which condensation will normally form. Figure 3.

By working closely with your GEMS representative, there are many design considerations that can help lessen the effects of moisture.

1. Consider a product such as the GEMS LS-270 Single Level Switch which has a water-tight molded cable.
2. Consider using a unit with a connector and gasket seal.
3. Consider using moisture resistant heat shrink tubing on the switch capsule assembly.
4. Consider using Scotchcast® 2114 sealing compound and electrical insulator. Part No. 157636.

A WORD OF CAUTION: Most of GEMS level products incorporate a potting cap or are fully potted. Due to the bonding characteristics of the potting to the wire leads, there is no way of assuring a water tight seal at the potting joint. Our potting cap will resist moisture to some degree, but the precautions mentioned above should be used to assure moisture doesn't enter the switch and cause a short.

Please refer to Gems Instruction Bulletins for detailed installation and maintenance procedures. Instruction Bulletins are available at www.GemsSensors.com

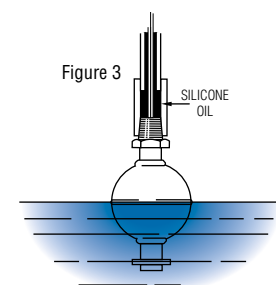
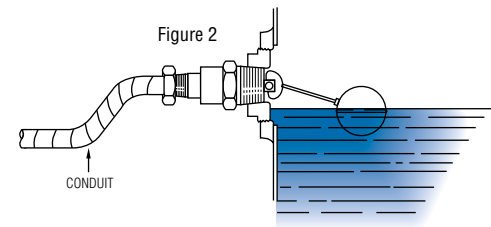
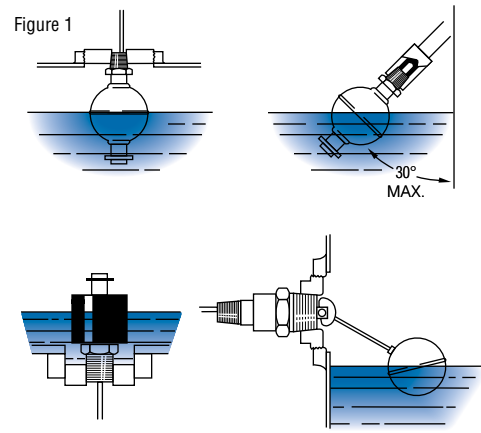

Thread Treatment

Sealing

When threading metal threads into a metal coupling, pipe sealant or Teflon® tape is recommended. Due to potential compatibility problems, when sealing plastic threaded units, a compatible pipe sealant such as **No More Leaks™** from Permatex® is recommended.

Tightening

When threading a plastic level switch into a metal coupling, the installer should use a suitable wrench and tighten the threads 1 to 1-1/2 additional turns past hand tight. Over torquing of the threads will result in damage to the plastic mounting plug.

The Effect of Thread Engagement on Actuation Points

The length of mounting threads engaged at installation is important in calculating switch actuation points and the actual length of stem extending into the tank. Use the chart below to find the thread engagement length (T) for a given NPT size. Factor the T dimension into any calculation of switch actuation levels (L) and overall length (L₀).

T Dim.	NPT							
	1/8"	1/4"	1/2"	3/4"	1"	1-1/4"	2"	3"
	.27"	.39"	.53"	.55"	.68"	.71"	.76"	1.20"

Examples: To solve for "L" use the formulas shown in the examples below. To calculate the Actual Tank Intrusion, substitute the L₀ value in place of L₁ in any of the formulas.

Internally Mounted – Standard Length

LS-1900 Series internally mounted through a 1/4" NPT hole.
To calculate L dimension:

$$L = L_1 + (A - T)$$

$$L = 1-3/16" + (21/32" - .39")$$

$$L = 1.46"$$

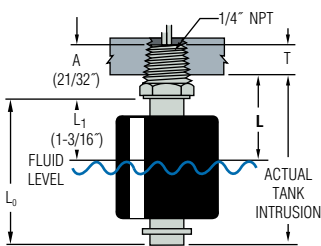

Internally Mounted – Configurable Length

LS-800 Series (Type 1) internally mounted through a 1/2" NPT hole.
To calculate L dimension:

$$L = L_1 + (A - T)$$

$$L = 6" + (1-1/4" - .53")$$

$$L = 6.72"$$

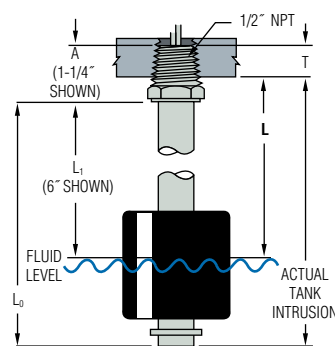

Definition of Variables Used in Examples Below

A = Mounting length.

T = Thread engagement.

P = Distance from coupling (bung) top to inside surface of tank or bracket.

L = Switch actuation level as measured from inside surface of tank or bracket to fluid surface.

L₁ = Switch actuation level, nominal, as measured from bottom of mounting (based on a liquid specific gravity of 1.0).

Externally Mounted – Configurable Length

LS-700 Series (Type 3) externally mounted through a 1" NPT hole. To calculate L dimension:

$$L = L_1 - (P - T)$$

$$L = 6" - (1" - .68")$$

$$L = 5.68"$$

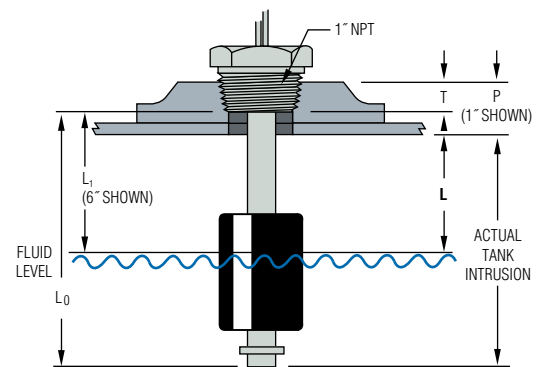

No More Leaks is a trademark of Permatex® Industrial Corp., a subsidiary of Loctite Corp.
Teflon is a registered trademark of DuPont Corp.

Reed Switch Protection

The hermetically-sealed reed switch used in GEMS level switches are extremely rugged and designed to operate reliably for many years – 2 million cycles under ideal conditions. To achieve the maximum service life, reed switches benefit from protected electrical supply.

IMPORTANT:

- Don't be misled by the resistive ratings of the switches. Most applications involve inductive loads.
- Don't be misled by the wattage ratings of loads. Low wattage loads are often high inductive devices, making contact protection very important.

Contact Protection Requirements

When switching inductive loads such as relays, solenoids and transformers, reed switch contacts require protection in order to ensure long, dependable life. When current is interrupted, the inductance or electrical inertia of the load generates a large high frequency voltage, which appears across the switch contacts. If the voltage is large enough, it can break down the medium in the gap between them, making a conductive path. This phenomenon, called "arcing," is the spark you see. Arcing can cause the contacts to burn, weld together or stick; thus, giving unreliable performance. The purpose of protection circuits is to prevent arcing, by shorting this voltage through an alternate path.

Recommended Protection

D.C.

A 1N4004 diode (or equivalent) connected cathode-to-positive, as shown in Figure 1, is recommended. The diode does not conduct when the load is energized, but conducts and shorts out the generated voltage when the switch opens. The generated voltage always acts in series with the applied voltage.

A.C.

A resistor and capacitor, connected in parallel with the switch, as shown in Figure 2, is recommended. The capacitor is a high impedance to 60 hertz, but is essentially a short circuit to high frequencies of generated voltages.

Transient suppressors or varistors may also be used to dissipate the transient and protect the switch contacts.

Notes:

1. Don't be misled by low voltage $\leq 10V$, low current $\leq 1MA$ type of loads. These loads may require special gold plating on contact surfaces to operate reliably at these low voltage/low current levels. For long term reliable low current switching action, Gems 20VA switches should be operated at a minimum of 12V to assure contact make; e.g., break through an oxide film which may form over long periods of time.
2. Incandescent lamp loads are very destructive to reed switch applications. These type of loads have a 6-10 time the normal operating current (inrush current) when first energized. This high current level is a prime factor which decreases the life of the switch.
3. The following rating may be used for selection.

$$V_{RMS} = 130 \text{ volts} \quad \text{Energy} = 30\text{-}50 \text{ joules} \quad \text{Peak Amps} = 4000\text{-}6000$$

The dependable reed switch is at the heart of most level switch shown in this catalog.

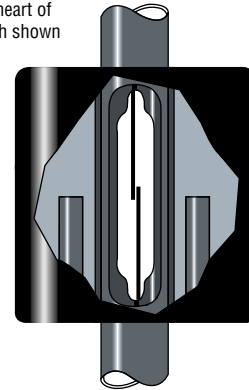

Figure 1
D.C. Contact Protection
(Drain the Load)

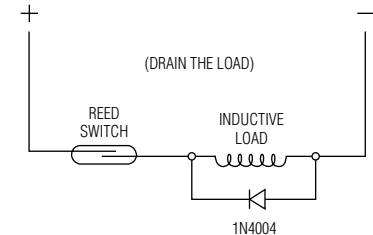
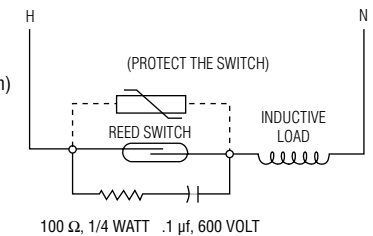

Figure 2
A.C. Contact Protection
(Protect the Switch)



Junction Boxes

GEMS offers optional CSA Listed and FM Approved, explosion-proof junction boxes for many level switch models. Compatible level switches are indicated throughout this catalog by the small icon—.

NOTE: Explosion-proof ratings are available only when J-boxes are part of factory assembled sensor unit. J-boxes below, when ordered separately, do not carry explosion-proof ratings.

Pyromation®

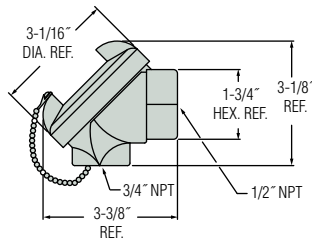



	Aluminum	Iron
Materials	Die Cast Aluminum	Cast Iron
	Stainless Steel Chain and Pin	
	EPDM Rubber Gasket (300°F/149°C Max. Service Temp.)	
Finish	Polished	Electroless Nickel Plate
Weight (approx.)	.62 lbs.	.62 lbs.
NEMA Rating	4, 13	4
Part Number	192147	198848

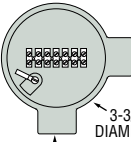
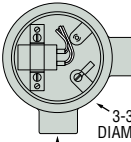
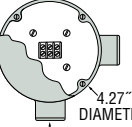

© Pyromation is a registered trademark of Pyromation, Inc.

Non-Explosion Proof J-Boxes

	Alloy		Plastic		
					
	3-3/4" DIAMETER	3-3/4" DIAMETER	4.27" DIAMETER		
	1/2" TRADE SIZE (2 PORTS)	1/2" TRADE SIZE (2 PORTS)	1/2" NPT 2 PORTS		
Type	3-pin	7-pin	DPDT Relay	3-pin	7-pin
Part Number	113873 ⚡	113877 ⚡	75980	113850	118828

⚡ – Stock Items.

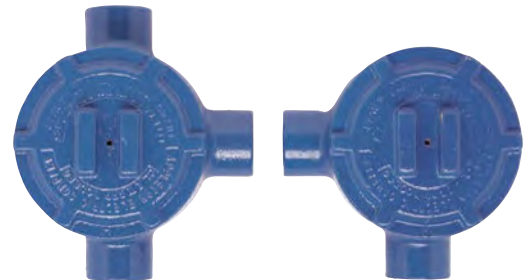

Junction boxes are CSA and FM approved for explosion proofing in Class I, Division 1, Groups B, C, D, E, F, G

Conduit/Cable Gland Connections

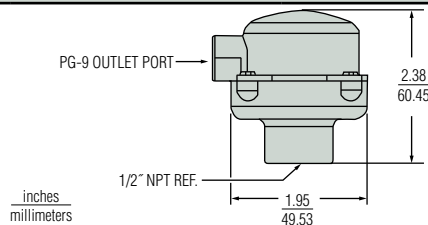

	Standard	5-Amp Relay
Specifications	Empty enclosure for lead wire splice connections.	120 VAC 50/60 HZ Contacts: 5A – 240 VAC Res 1/3 HP – 120 VAC 5A – 28 VDC Res.
Part Number	181410	180417



Order from: **C A Briggs Company**; 622 Mary Street; Suite 101 - Warminster, PA 18974
Phone: 267-673-8117 - Fax: 267-673-8118; E-Mail: Sales@cabriggs.com - www.cabriggs.com

Electrical Data

Standard reed switches in GEMS level and flow switch units are hermetically-sealed, magnetically actuated, make-and-break type. Switches are SPST or SPDT, and rated 20 VA. See the chart below for maximum load characteristics of GEMS level switches.

GEMS Sensors Inc. would be pleased to run life tests on our level or flow switches with your specific load, and issue a report indicating the approximate number of cycles that can be expected. U.L. Recognized Units: Switches showing a U.L. listing are rated for 10 VA or 20 VA as shown below.

Switch Rating – Maximum Resistive Load

VA	Volts	Amps AC	Amps DC
10 General Use	0-50	.2	.13
	120	.08	N.A.
	100	N.A.	.1
20 Pilot Duty	0-30	.4	.3
	120	.17	.13
	240	.08	.06
50 ¹ General Use	0-50	0.5	0.5
	120	.4	.4
	240	.2	.2
100 ¹	120	.8 ²	N.A.
	240	.4	N.A.

Notes:

1. Level switch units with 50 VA and 100 VA switches are not U.L. Recognized or CSA Approved.
2. Limited to 50,000 operations.

Typical Wiring Diagrams

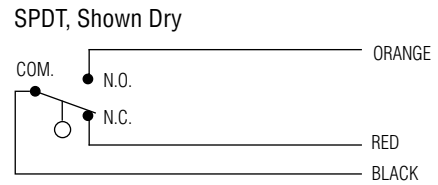
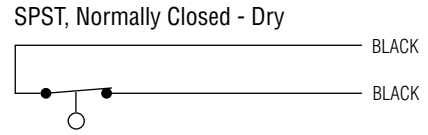
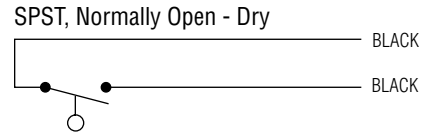

Glossary of Terms

Absolute Pressure: Pressure measured relative to absolute zero pressure. Usually stated in terms of psia, torr or mm Hg.

Air, Dry: Air that has most of the moisture removed and has not been lubricated with oil.

Air, Lubricated: Air or gas that has had an oil mist injected into the system.

Alternator: A device that alternates between two or more pumps or solenoid valves.

Ampere: The basic unit of electrical current (amp).

AST: Above Ground Storage Tank.

Atmospheric (Barometric) Pressure: The pressure caused by weight of the Earth's atmosphere. It is altitude specific and can also be influenced by localized weather systems. For this reason, standard seal level conditions are defined as 14.7 psi or 29.92 Hg of absolute pressure.

Ball Float: Type of float that has an embedded magnet.

Bar: Unit of pressure (or stress). 1 bar = 750.07mm of mercury at 0°C, lat.45°.

Bourdon Tube: An early, mechanical pressure gauge consisting of a flattened tube that tends to straighten under internal pressure; today usually used with a potentiometer to produce an electrical output.

Bubbletight Valve: No leakage past the internal seals of a valve in a 5-second soap bubble test.

Burst Pressure: The pressure at which catastrophic failure of the sensing element, mechanical interface or pressure switch enclosure is expected to occur. Because of safety concerns, a product with a burst pressure of at least twice the maximum pressure of the application should be chosen.

Valve Buzz: A persistent vibratory sound usually caused by the plunger not staying in contact with the stop (AC valves only).

Capacitive Sensing: Detection and measurement of pressure through the change in voltage across a capacitor, one plate of which is a diaphragm which deflects slightly with changes in applied pressure.

Compound Pressure: Pressure measured from full vacuum (-14.7 PSIV) to gage pressure, referencing atmosphere.

Conductive Liquid: Any liquid which allows electricity to pass through it.

Conductivity: A method for sensing liquid level. Using a special control, electrical current is passed through the liquid from one probe to another, causing the control to change state electrically.

Conformal Coating: Non-conductive coating used on circuit boards to reduce electrical shorts that may be caused by excessive humidity.

Contacts: Electromechanical components that complete or break a connection between two conductors that permit a flow of current. There are four types of contacts in Warrick controls.

SPDT: Single Pole Double Throw contacts. A common point with contact points that give one normally open and one normally closed contact (Form C contacts).

DPDT: Double Pole Double Throw contacts. Two isolated sets of contacts, each consisting of one SPDT (two Form C contacts).

N.O.: Normally Open contacts. Contact points that are open when relay is in non-powered state.

N.C.: Normally Closed contacts. Contact points that are closed when relay is in non-powered state.

Controller: A Warrick device used to regulate a process based on input parameters.

CSA: Canadian Standards Association, a testing laboratory for products sold in Canada.

Deadband: The arithmetic difference in pressure between the rising pressure (or vacuum) setpoints and the falling pressure (or vacuum) setpoints. All electromechanical pressure switches exhibit a deadband. Minimum and/or maximum deadbands are often specified so that a pressure switch can be used as a cost effective control method in pneumatic and hydraulic systems.

De-energized Valve: The "normal" state of a valve. The condition of an electrically operated valve when no current is being applied.

Differential Pressure: The difference in pressure between two different pressures one of which is not usually defined as absolute zero pressure or atmospheric pressure.

Differential Pressure Switch: A pressure switch with two distinct pressure interfaces (ports) that electromechanically compare the pressures. All pressure switches detect differential pressure because a pressure differential must exist to generate enough force to actuate the mechanism. However, they do not have two distinct pressure interfaces.

Direct Mode: Direct Mode controls energize relays when the liquid level reaches the highest probe (typically used in pump down applications to drain vessels).

DPDT: Double Pole Double Throw contacts. Two isolated sets of contacts, each consisting of one SPDT (two Form C contacts).

Dual Function: A special Warrick unit that provides control for two separate functions. Combining a Series 16 control with a Series 26 control on a single circuit board allows one differential level control and a low-water cutoff.

Duplex: Pump system that includes motor starters for two pumps (may also include alternator).

Electrical Enclosures: Safety rated electrical boxes, which can be NEMA 1, NEMA 3, NEMA 4, NEMA 7, or NEMA 12 for Warrick products.

NEMA 1: General purpose (indoor)

NEMA 3R: Rainproof, sleet resistant (outdoor)

NEMA 4: Water tight, dust tight, sleet resistant (indoor or outdoor)

NEMA 4X: Water tight, dust tight, sleet resistant, corrosion resistant (indoor or outdoor)

NEMA 7: Class 1, Group A, B, C or D hazardous locations, air-break (indoor)

NEMA 12: Industrial use, dust tight and drip tight (indoor)

Electrode: Same as probe.

Energized Valve: When current is flowing through the coil and resulting magnetic flux is sufficient to draw the plunger up against the stop.

Fitting: Warrick control system component designed to hold one or more probes.

FM: Factory Mutual, a testing agency for products sold in the United States.

FS: (Full Span or Full Scale) The range of measured values over which a transducer is intended to measure, specified by the upper and lower limits. Ex: 0 to 100 PSIG, FS is 100 PSIG/0 to 5 VDC. FS is 5 VDC, 800-1100 MB, FS is 300 MB.

Gauge Pressure: Pressure measured relative to atmospheric pressure. Most setpoints are specified in gauge pressure because it provides an automatic method of offsetting atmospheric pressure variations caused by altitude and weather. Usually expressed in terms of psig or bar.

Ground: Point of an electric circuit that is at zero volts potential relative to the earth.

Heat Rise: The difference between the stabilized temperature of the solenoid coil when energized and the stabilized temperature when de-energized.

Housing, Conduit: Valve coil enclosure with boss for connection to electrical conduit.

Housing, Grommet: Valve coil enclosure with grommet protection of the coil leadwires.

Hysteresis: The difference in the deadband that results from changing the points at which the setpoints are determined from. For example, a pressure switch set at 30 psi on falling pressure can be checked on a test stand from 40 psig or 3000 psig. Both methods will result in slightly different results. Hysteresis is more common and more pronounced on elastomer diaphragm units.

Intrinsically Safe: Control unit that is incapable of generating a spark. This type of control is typically used to interface with equipment which is exposed to hazardous atmospheres.

Inverse Mode: Indirect (inverse) mode controls energize relays when the liquid level drops below the lowest probe (typically used in pump up applications to refill vessels).

Leak Detection: The monitoring of liquid either in an interstitial or non-interstitial environment.

Life: Usually defined as the number of pressure cycles (0 psig - desired pressure - 0 psig) that a pressure switch can endure while both maintaining its setpoint within the stated repeatability range and reliably switching the desired electrical load. Cycle life varies greatly with each application and is best determined through long term testing in the actual system. Gems frequently provides hydraulic and pneumatic life testing upon request.

Load: Motor, alarm, or solenoid that is controlled by a Warrick liquid level control system.

LWCO: Low-Water Cutoff. A control that shuts down a pump, solenoid, burner or other device when water drops below set point.

Manometer: An early instrument for measured pressure; originally, a U-shaped tube containing liquid (water, oil or mercury), one limb opening to the gas volume to be measured, the other closed or connected to a registered or recording instrument. Modern versions utilize diaphragms, bellows or other devices for sensing relative pressures.

Media: The fluid or gas which flows through a sensor or valve.

Micro-Mohs: Measurement of electrical conductivity for a liquid medium.

Module: A type of control that encases a circuit board in a plastic housing and connects quickly with an 8-pin or 11-pin socket to provide easy installation wiring.

MOPD: Maximum Operating Pressure Differential. The maximum difference between the pressure at the inlet port and the pressure at the outlet port at which a solenoid valve will operate.

Motor Starter: Contactor required to start motors and protect them from excessive current during start and run.

NEMA: National Electric Manufacturers' Association, a group which sets standards for the United States.

Millibar: (mbar) Unit of pressure generally used in a barometric measurement; 1 mbar = 100 N/m², or 10⁻³ dyn/cm².

Newton: (N) The unit of force in the International System of Units (SI); the force required to impart an acceleration of 1 m/sec² to a mass of 1 kg.

Normally Closed: (NC/SPST) A two wire or two terminal electrical switching element that allows current to flow until pressure is applied to open the circuit.

Normally Open: (NO/SPST) A two wire or two terminal electrical switching element that does not allow current to flow until pressure is applied to close the circuit.

Ohm: A unit of measurement for electrical resistance and impedance. A conductor has a resistance of 1 ohm when a current of 1 amp flows through it with a potential of 1 volt across its terminals.

Oil Water Separator: Tank which allows the natural separation of oil and water to occur and allows oil to be removed.

Operator: A solenoid valve without the valve body. The operator would be installed into a threaded, orificed cavity of a manifold having ports.

Orifice, Body: The main opening or passage in the valve body through which fluid flows.

Orifice, Stop: Valve orifice located in the stop of the guide assembly.

Oxygen Service: Application where oxygen is the media flowing through the valve. This service requires the valve be specially cleaned.

Pascal: (Pa) The standard unit of pressure (or stress) in the SI system; equal to 1 newton per square meter (1 N/m²).

P/I: Term common to process industries meaning pressure-in/current-out. (3-15 PSIG Input to 4-20 mA DC Output).

Pilot Panel: Enclosed controls which act only to signal external motor starters or starting devices.

Plunger Seal: A material that is used on the end of a plunger assembly to seal an orifice or fluid path in a valve.

Point Level: Type of level control that turns a device On or Off when liquid rises or falls below a single preset point.

Port, Cylinder: The port that provides a passage to or from the valve to a cylinder inlet port.

Port, Exhaust: The port that provides a passage to the atmosphere or exhausting piping.

Port, Inlet: The port that provides a passage from the source fluid. Also called pressure port.

Port, Normally Closed: The port closed to fluid flow when the valve is de-energized.

Port, Normally Open: The port open to fluid flow when the valve is de-energized.

Port, Outlet: The port that provides the exit from the valve for the fluid.

Port, Over Seat: The valve body port located above the body orifice.

Port, Stop: The port located in the stop of the valve.

Port, Under Seat: The valve body port located below the body orifice.

Pressure, Back: The pressure encountered by the downstream side of a system component.

Pressure Differential: The difference in pressure between two points in a system or a component.

Pressure, Operating: Actual measured pressure in a specific valve application.

Pressure, Rated: The maximum operating pressure or pressure differential which is recommended for a component or system.

Pressure Sensing Element: The portion of the pressure switch that is in contact with and moves as a result of a change in pressure of the fluid. Gems uses a diaphragm/piston hybrid pressure sensing element.

Pressure Switch: An instrument that upon an increase or decrease in pressure (or vacuum) opens or closes one or more electrical switching element at a predetermined setpoint.

Pressure Transducer: An electromechanical device for translating fluid pressure valves into voltages across a high-impedance (5k ohms or greater) load.

Pressure Transmitter: An electromechanical device for translating fluid pressure values into currents (generally 4-20mA) into a low -impedance load. (Setra transmitters are designed by the model number prefix "C").

Primary Voltage: Supply voltage requirements (normally 120 VAC, 240 VAC, or 24 VAC).

Probe: Control system component that comes into contact with liquid.

Proof Pressure: The maximum pressure that can be applied to a pressure switch without causing mechanical degradation or the setpoint to shift.

PSIA: Pounds per square inch absolute.

PSIV: Pounds per square inch vacuum.

Range: The spread between the maximum and minimum pressures between which the transducer has been designed to operate.

Rectifier, Full Wave: A device that converts the negative wave of an AC voltage into a positive wave; therefore, approximating a DC voltage and eliminating the need for a shading ring. Rectifier can either be located externally in the lead wires or internally within the housing.

Reed Switch: An assembly containing ferromagnetic contact blades, hermetically sealed in a glass tube filled with inert gas. The switch is operated by an externally generated magnetic field from a permanent magnet.

Relay: An electromechanical device used to switch an electrical load On or Off. An energized relay allows current to flow between its common and normally open contacts.

Repeatability: The limit of deviation from the desired setpoint under a given set of environmental and operational conditions.

Reset: A switch (normally closed) used to reset a low-water cutoff relay.

Response Time: Elapsed time from the initial switch "ON" until the plunger is in the fully attracted position. Elapsed time from the initial switch "OFF" until the

plunger is in the fully detracted position.

SCFH: Standard Cubic Feet Per Hour. Generally used to measure the flow rate of gases.

SCFM: Standard Cubic Feet Per Minute. Generally used to measure the flow rate of gases.

Secondary Voltage: The low voltage portion of a probe that senses the presence or absence of liquid.

Sensitivity: The threshold for determining when a control senses that a probe is in water, it is normally expressed in terms of the conductivity or resistivity of the liquid.

Setpoint: The exact pressure at which the electrical circuit controlled by the switching element changes state. Setpoints can be specified on rising or falling pressure (vacuum).

Setraceram™: A patented, ceramic/glass sensing element, used by Gems in barometric transducers and instruments requiring the highest degree of measurement precision and stability.

Shading Ring: A copper or silver component inserted into the stop of AC voltage valves. It is required to hold the plunger positively against the stop and prevent buzz.

Simplex: Pump system which includes motor starter for a single pump.

Single Pole Double Throw: (SPDT) A three wire or three terminal electrical switching element that has one normally open (NO) and one normally closed (NC) circuit with no pressure applied. It can be wired as either an NC circuit, NO circuit or both.

Socket: Connector with 8-pin or 11-pin circular pattern that is used with module type control.

Solenoid Valve's Cycle Life: A term generally used to express the total life expectancy of a valve in cycles.

Solenoid Valve's Cycle Rate: The number of times a valve is capable of opening and closing in a particular time interval, usually one second.

Solenoid Valve's Duty Cycle: The longest time that a valve is energized, followed by the shortest time that it is de-energized, expressed as a percent as follows: (On Time/(On Time + OFF Time)) x 100.

Span: The algebraic difference between the limits of the range.
Ex: .1 to 5.1 Volts DC; span is 5 VDC. Sometimes used to designate full scale output; ie 5 VDC.

SPDT: Single Pole Double Throw contacts.

System Pressure: The pressure at which a system is normally expected to operate at, not including spikes or surges.

Time Delay: The period of time that a Warrick control will wait to change state after liquid leaves the probe (on rising level, the amount of time relay will wait after liquid contacts the probe).

Torr: A unit of low pressure equal to a head of 1 mm of mercury, or 133.3 N/2.

U.L.: Underwriter's Laboratories Inc., a testing agency for products sold in the United States.

UST: Underground Storage Tank

Vacuum: Any amount of pressure that is less than the atmospheric pressure. Usually expressed in terms of millibar, "Hg or psiv.

Vacuum, Low: Pressure at less than atmospheric pressure. 0 to -15 psi, or 0 to 29.5 in. Hg vacuum, or 760 to 25 Torr range.

Vacuum, Medium: Pressure at less than atmospheric pressure. 25 to 1x10⁻⁶ Torr range.

Vacuum, High: Pressure at less than atmospheric pressure. 1x10⁻⁶ to 1x10⁻¹⁷ Torr range.

Valve Body: Part of the valve that contains the inlet and outlet ports.

Valve Coil, Insulation Class: Identification of coils according to three general temperature insulating classes - Class B (130°C), Class F (155°C), and Class H (180°C).

Valve Coil, Encapsulated: A coil and housing that are assembled and filled with epoxy. Typically required for applications where vibration or moisture conditions present a problem.

Valve Coil, Molded: A coil that is encapsulated in a suitable resin.

Valve Coil, Tape Wrapped: A coil that is wrapped with electrical tape as the final insulation layer.

Valve Coil's Duty, Continuous: A rating given to a valve coil that can be energized continuously without overheating or failure under normal operating conditions.

Valve Coil's Duty, Intermittent: A coil not designated for continuous duty service, but which will perform satisfactorily for a specific duty service.

Valve, Direct Acting: A solenoid valve in which flow is controlled as a direct result of the plunger movement.

Valve, Latching: A solenoid valve which utilizes the flux of a permanent magnet to stay in its energized position without consuming any electrical power. "Latch" means plunger is up against stop orifice. "Un-Latch" means plunger is down against body orifice.

Valve, Isolation: A solenoid valve with an internal diaphragm separating the plunger and guide assembly from the fluid passing through the valve; therefore, the fluid contacts only the valve body material and the diaphragm material.

Valve, Solenoid: An electro-mechanical device that controls fluid flow direction, pressure, or flow rate.

Valve's Cv Factor: An orifice flow rate coefficient that represents the quantity of water, at 68°F and in GPM, which will flow through a valve with a 1 psi pressure drop.

Valve's Cycle: A complete operation of a solenoid valve, i.e., opening a normally closed valve and then closing it, equals one cycle.

Vented Pressure Switch: A pressure switch, usually with a low pressure or low vacuum setting, with a means to interface with the surrounding atmosphere. The vent allows the setpoint to remain stable despite changing temperatures, altitudes and atmospheric conditions. The vent also exposes the internal mechanical and electrical mechanism to the effects of the atmosphere.

Volt: The basic unit of measurement for electromotive force or potential difference.

Voltage, Hold: The voltage, equal to or less than nominal voltage, applied to the coil after a Spike Voltage to keep the valve energized.

Voltage, Nominal: The voltage for which the valve is rated should be applied to the coil of the valve.

Voltage, Spike: The voltage, greater than nominal voltage, applied to the coil for approximately 50 milliseconds to energize the valve. The voltage is then reduced to a Hold Voltage level.

How to Order from Gems Sensors & Controls

Gems® Sensors Inc. is dedicated to fast, efficient customer service and offers several ways for you to order from us. You may place your order on-line, by phone, fax or mail:

On-line: www.gemssensors.com
Toll Free: 1-800-378-1600
Or: 1-860-747-3000
Outside the U.S. Dial: 001-860-747-3000
Fax: 1-860-747-4244
Or Mail to:

Gems Sensors Inc.
One Cowles Road
Plainville, CT 06062-1198

Visa, MasterCard and American Express accepted.

Additionally, you may place your order through the Sales Partner nearest you. Sales Partner locations can be found at www.gemssensors.com

Terms and Conditions

See our complete Terms and Conditions of Sale at www.gemssensors.com

Sales Hours

Our technical sales representatives are available 8 AM to 4:30 PM Eastern Time Monday through Friday.

Discounts

Many Gems products have quantity discount schedules. Contact a sales representative to discuss your requirements and learn how to qualify for discounts.

Additional Gems Offices

China

Danaher Setra-ICG (Tianjin) Co., Ltd.
Room.502, Building 6, Lane 280 Linhong Road,
Changning District, Shanghai 200335
Tel: +86 400 666 1802
Fax: +86 21 61289877
Email: gems.sales@danaher.com

Japan

Danaher ICG Japan
2-12-23 Minami-Kaneden, Suita
Osaka 564-0044
Tel: +81-6-6386-8001
Fax: +81-6-6386-5022
Email: csinfo_dicgj@danaher.co.jp

United Kingdom

Gems Sensors
Lennox Road
Basingstoke, Hampshire, RG22 4AW
England
Tel: +44 (0) 1256 320244
Fax: +44 (0) 1256 473680
Email: sales@gems-sensors.co.uk