

Humidifier Solenoid Valves

- ▶ MOPD: 125 PSI (8.6 bar)
- ▶ 2.3 Watts

Originally designed and manufactured for original equipment manufacturers (OEM's), the humidifier solenoid valve is now available as a replacement solenoid valve for in-home and commercial humidifiers. Available in two orifice sizes, the humidifier solenoid has a brass body and is constructed with an in-line strainer for added protection to humidifier water lines.

Typical Application

- Replacement solenoid valve for commercial and in-home humidifiers



Dimensions

24V, 60Hz AC

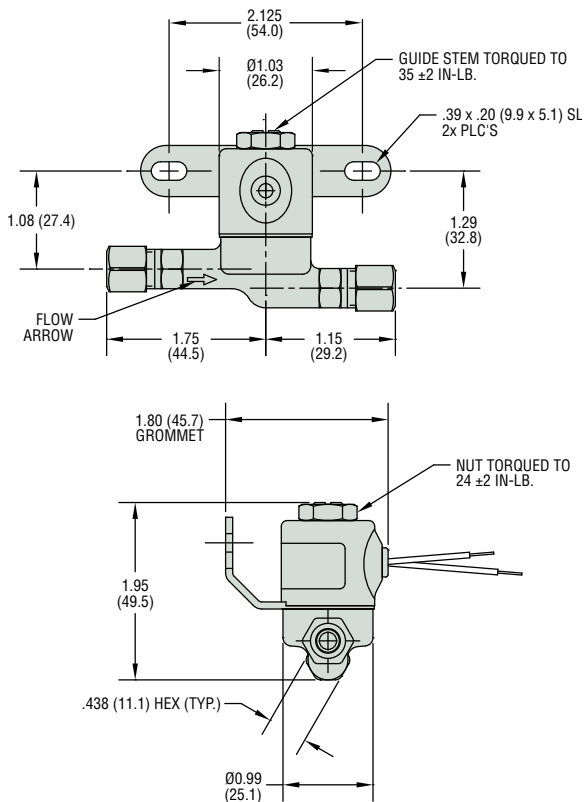

120V, 60Hz, AC

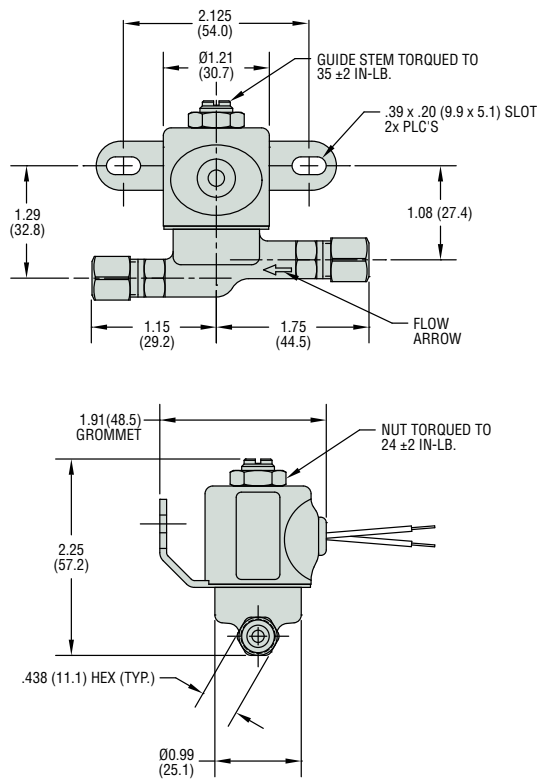

How To Order

Orifice		Voltage (VAC)	MOPD		Part Number
inch	mm		psi	bar	
3/64	1.19	24/60	125	8.6	A2012-S150
3/32	2.38	120/60	125	8.6	B2015-S135