

## UCL-520 — 2-Wire Transmitter for Midsize Tanks

- ▶ To 26-feet (8m) range with 2" transducer
- ▶ 2" NPT mounting
- ▶ Setup is fast and easy. Incorporates push button calibration and LCD display
- ▶ 6-segment LCD display indicates level in inch or centimeter values
- ▶ 7.6 cm minimum beam width for applications with restricted space
- ▶ Fail-safe intelligence with diagnostic feedback for easy troubleshooting

The UCL-520 is a general purpose two-wire ultrasonic transmitter providing non-contact level measurement up to 26.2' or 8m. It is ideally suited for challenging ultrapure, corrosive or waste liquids.

Push button calibrated, the UCL-520 is broadly selected for atmospheric bulk storage, day tank and waste sump applications. Media examples include wastewater and sodium hydroxide. The PC/ABS enclosure is rated NEMA 4X, and the transducer is housed in rugged PVDF.

### Specifications

<b>Range</b>	6' to 26.2' (1.8 m to 8 m)
<b>Accuracy</b>	± 0.2% of span in air
<b>Resolution</b>	0.039" (1 mm)
<b>Beam Width</b>	3" (7.6 cm) dia.
<b>Dead Band</b>	8" (20 cm)
<b>Display Type</b>	LCD, 6-digit
<b>Display Units</b>	Inch, cm or percent
<b>Display Mode</b>	Air gap or liquid height
<b>Memory</b>	Non-volatile
<b>Supply Voltage</b>	12-28 VDC
<b>Loop Resistance</b>	500 Ohms @ 24 VDC
<b>Signal Output</b>	4-20 mA, two-wire
<b>Signal Invert</b>	4-20 mA or 20-4 mA
<b>Calibration</b>	Push button
<b>Fail-Safety</b>	Selectable 4 mA, 20 mA, 21 mA, 22 mA or hold
<b>Process Temp.</b>	-7°F to +140°F (-20°C to +71°C)
<b>Temp. Comp.</b>	Automatic
<b>Electronics Temp.</b>	-40°F to +160°F (-40°C to +71°C)
<b>Pressure</b>	30 PSI (2 bar) @ 25°C, derated @ 1.667 PSI (0.113 bar) per °C above 25°C
<b>Enclosure Rating</b>	NEMA 4X (IP65)
<b>Enclosure Vent</b>	Water tight membrane
<b>Enclosure Material</b>	PC/ABS FR
<b>Trans. Material</b>	PVDF
<b>Process Mount</b>	2" NPT (2" G)
<b>Mount. Gasket</b>	Viton®
<b>Conduit Entrance</b>	Dual, 1/2" NPT
<b>Classification</b>	General Purpose
<b>CE Compliance</b>	EN 61326 EMC



### Typical Applications

- Water and Waste Water
- Petrochemical
- Health Care
- Mining
- Cleaning
- HVAC
- Chemical
- Semiconductor
- Agriculture
- Electric Power
- Water Parks/Swimming Pools

Dimensions

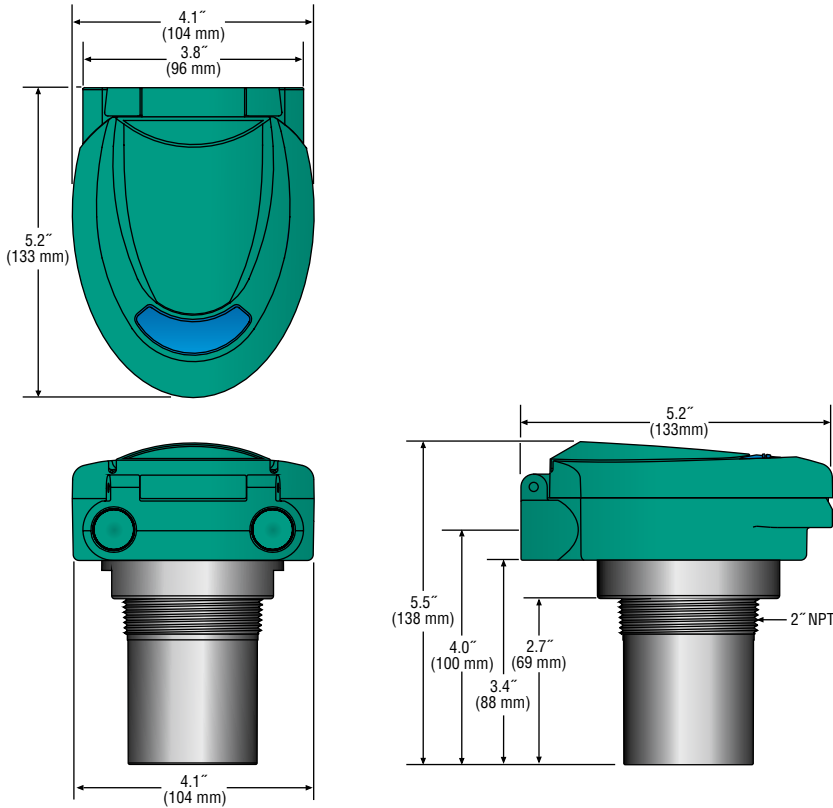

Easy Calibration



Calibration is fast and simple with our scrolling single layer menu, three button interface and 6-segment LCD display. Troubleshooting is easy with our unique Setup and Diagnostic feedback modes. Setup displays the transmitter's calibration set points. Diagnostics provides users with a snapshot of sensor performance and application variables. Gems UCL-520 is full feature level sensing made simple.

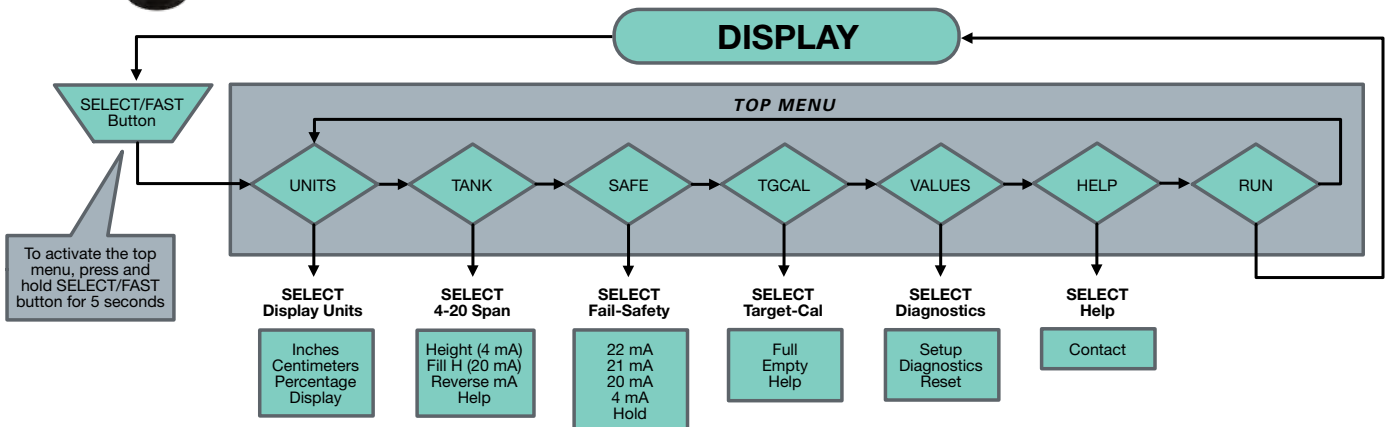

How To Order

Select by Part Number.

Description	Part Number
UCL-520 2-Wire Transmitter	225200

Order from: **C A Briggs Company**; 622 Mary Street; Suite 101 - Warminster, PA 18974  
 Phone: 267-673-8117 - Fax: 267-673-8118; E-Mail: [Sales@cabriggs.com](mailto:Sales@cabriggs.com) - [www.cabriggs.com](http://www.cabriggs.com)